



SELF-CONTAINED CUBER

## PARTS LIST

[HE] [GRAM] [HS]

E1EC

E1EC-D001,D002,D003,D004,D005,D006,D007,D020

A-1 AUG. 2011  
B-1 JAN. 2012  
B-2 JUN. 2012  
B-3 ----- 2012  
B-4 OCT. 2012  
F-0 JAN. 2016 (From F00001 to F01133)  
F-0 APR. 2016 (From F01134)  
G-1 APR. 2017  
G-2 OCT. 2017  
J-1 JUL. 2019  
J-2 SEP. 2019  
K-1 JAN. 2020

IM-240NE  
IM-240NE-21  
IM-240NE-23  
IM-240WNE  
IM-240WNE-23  
IM-240NE(HS)  
IM-240NE-21(HS)  
IM-240NE-23(HS)

E1EC-3584 (0320)

## List of Specifications

IM-240NE	E1EC	Standard
IM-240NE-23	E1EC-D001	23mm ICE of IM-240NE
IM-240NE-21	E1EC-D002	21mm ICE of IM-240NE
IM-240WNE	E1EC-D003	Water cooled
IM-240WNE-23	E1EC-D004	For HE, 23mm ICE of IM-240WNE
IM-240NE(HS)	E1EC-D005	For Singapore special water valve
IM-240NE-23(HS)	E1EC-D006	23mm ICE for Singapore special water valve
IM-240NE-21(HS)	E1EC-D007	21mm ICE for Singapore special water valve
IM-240NE	E1EC-D020	For GRAM



**PLATON SERVICE**

8 (800) 500-34-47

[www.platonservice.com](http://www.platonservice.com)

## AUXILIARY CODE

U - 1

The auxiliary code is the first two characters in the serial number. The first character indicates the production year. Years progress or regress in alphabetical order. The series of letters and skipped letters depend on UL listing, production, and model. See the auxiliary code(s) and corresponding year(s) on the front cover.

The second character indicates significant part changes within the same year. Base is "1" and this number advances for each change. If there is no significant part change at the turn of the year, this number starts from "0."

## MARKS LOCATED UNDER THE AUXILIARY CODE

- = Part deleted.
- x = Part deleted and replaced by "o" part.
- o = New part in place of "x" part.

## FASTENER PART NUMBER

### SCREWS



F S T 0 3 0 6 F 0

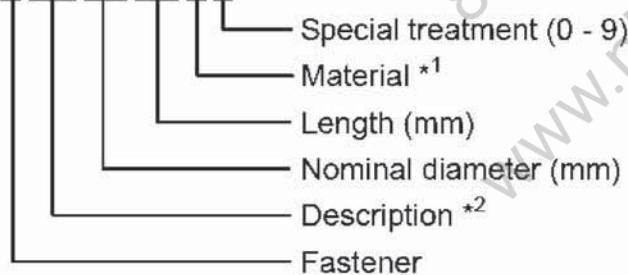

\*<sup>1</sup> Material

- F: Steel
- S: Austenitic stainless steel
- M: Martensitic stainless steel
- B: Copper alloy
- P: Polycarbonate
- N: Polyamide
- V: PVC
- A: ABS
- X: Polyacetal
- L: Aluminum

### NUTS & WASHERS

F W S P 0 5 S 0

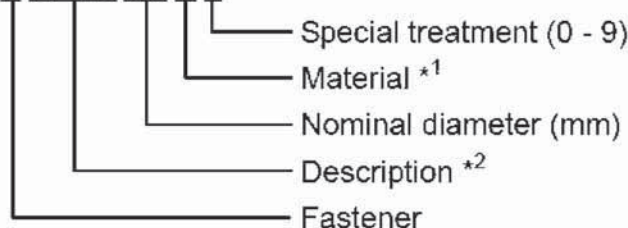

\*<sup>2</sup> Description

- First letter
- S: Machine screw
- T: Tapping screw
- M: Wood screw
- B: Bolt
- W: Washer
- N: Nut

IM-240NE(-21,-23)  
IM-240WNE(-23)

A. ICE CUBBER ASSY (1/2) (A-1) and later

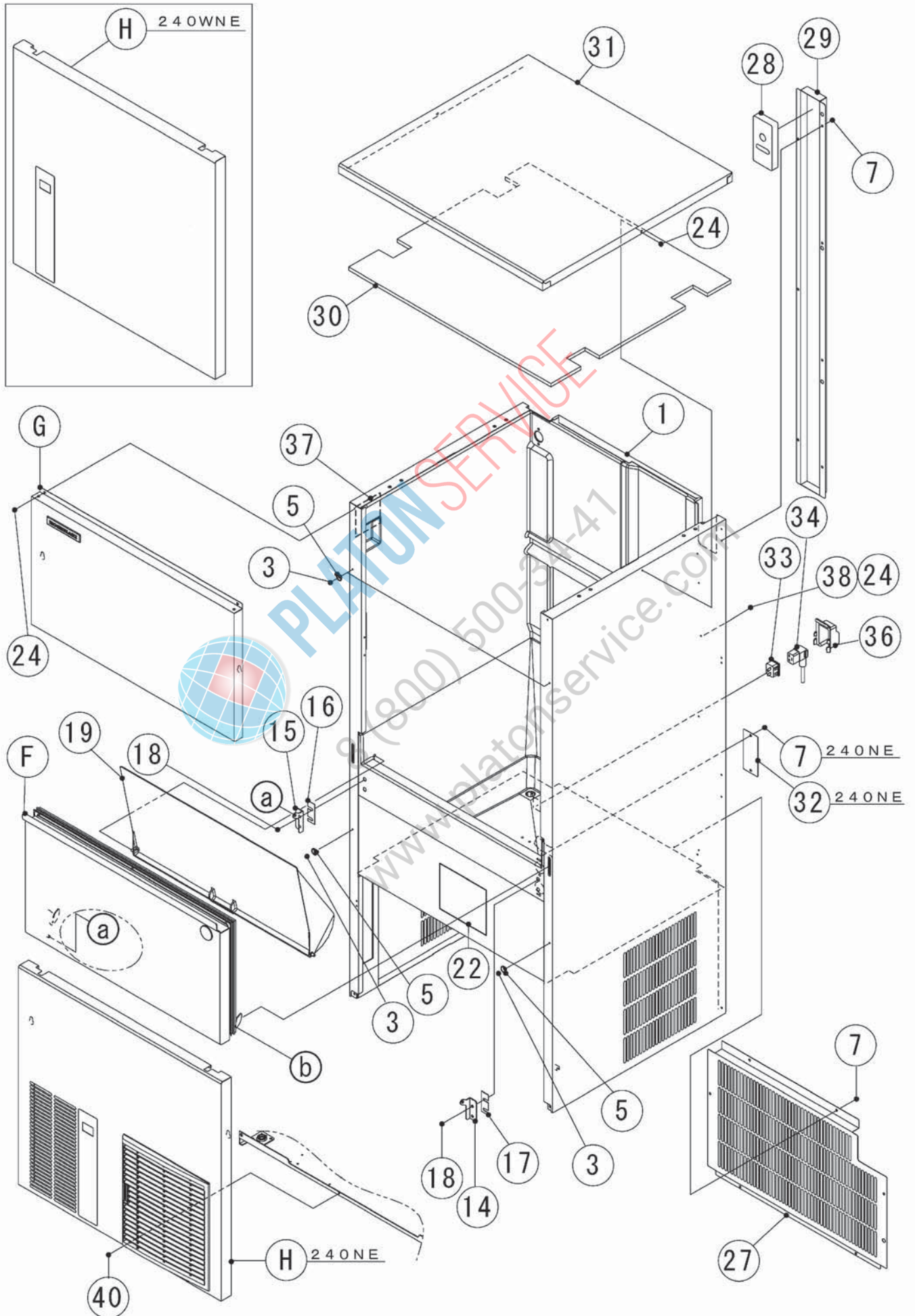

IM-240NE(-21,-23)  
IM-240WNE(-23)

A. ICE CUBBER ASSY (2/2) (A-1) and later

IM-240WNE

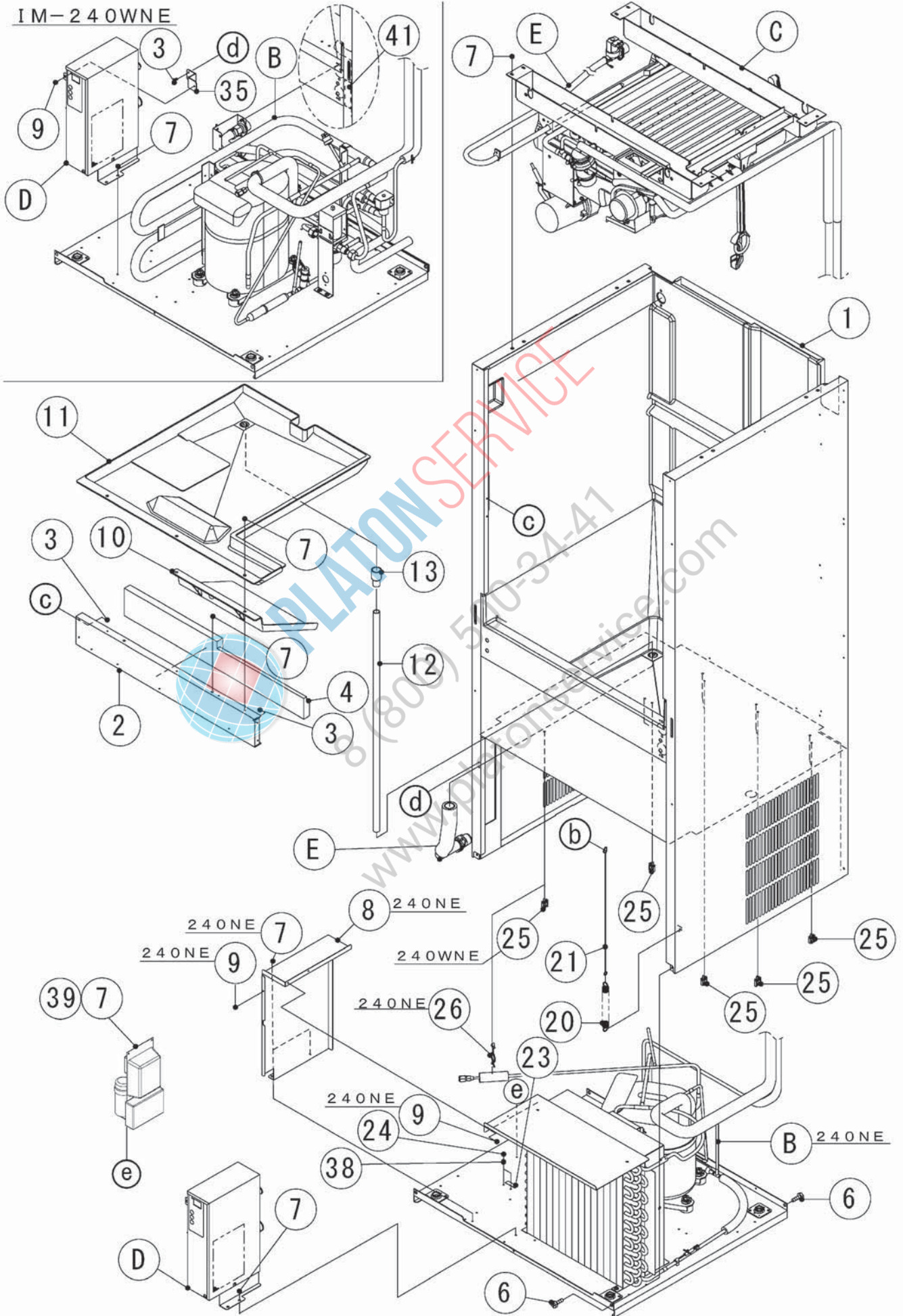

MODEL: <b>IM-240NE,-21,-23</b> <b>IM-240WNE,-23</b>			TITLE: <b>A.ICE CUBBER ASSY</b>					
INDEX NO.	DESCRIPTION	MATERIAL OR MODEL NUMBER	PART NUMBER	REQ'D NUMBER				
				A-1 B-1	B-2 B-3	B-4 F-0 (Note1)	F-0 (Note2) G-0	G-1
B	REFRIGERATION ASSY	(240NE,-21,-23)	1H4761A01	1	-	-	-	-
			1H5213A01	-	1	1	1	1
		(240WNE,-23)	1H4791A01	1	-	-	-	-
			1H5216A01	-	1	1	1	1
C	MECHANISM ASSY		1H4762A01	1	1	1	1	1
D	CONTROL BOX ASSY	(240NE,-21,-23)	2X0291A01	1	-	-	-	-
			2X1197A01	-	1	1	1	1
		(240WNE,-23)	2X0366A01	1	-	-	-	-
			2X1197A02	-	1	1	1	1
E	WATER CIRCUIT ASSY		2X0293A01	1	1	1	1	1
F	DOOR ASSY		3Y5436A01	1	1	1	1	1
G	FRONT COVER UPPER ASSY		3Y5438A01	1	1	1	1	1
		(GRAM)	3Y5438A02	-	-	1	1	1
H	FRONTCOVER(LOWER) ASSY	(240NE,-21,-23)	3Y5439A01	1	-	-	-	-
			2X1261A01	-	1	1	1	1
		(240WNE,-23)	3Y5544A01	1	-	-	-	-
			3Y6776A01	-	1	1	1	1
M	ACCESSORIES			1	1	1	1	1
1	BODY		1H4759G01	1	1	1	1	1
2	FRONT FRAME		3X9103-01	1	1	1	1	1
3	RIVET		7170-0002	8	8	8	8	8
4	INSULATION - FRONT FRAME		4Y6991P01	1	1	1	1	1
5	TAPER COLLAR		4H0171-01	4	4	4	4	4
6	T2 SCREW	(240NE,-23)	1H4766-01	4	-	-	-	-
		(240WNE)	1H4794-01	4	-	-	-	-
	TAPPING SCREW - HEX		442040-01	-	4	4	4	4
7	FLANGE BOLT (C-TITE)	(240NE,-21,-23)	FTR0408M0	32	-	-	-	-
				-	34	34	34	34
		(240WNE,-23)		29	-	-	-	-
				-	32	32	32	32
8	COVER - CONT	(240NE,-23)	2X0292M01	1	-	-	-	-
9	TRUSS HEAD TAPPING SCREW T2	(240NE,-23)	FT20408F0	3	-	-	-	-
		(240WNE)	FT20408F0	1	-	-	-	-
10	ICE GUIDE G		4Y7002G01	1	1	1	1	1
11	DRAIN PAN		3Y5434G01	1	1	1	1	1
12	DRAIN PIPE		4X7117-02	1	1	1	1	1
13	DRAIN TUBE		4H2585-01	1	1	1	1	1

MODEL: <b>IM-240NE,-21,-23</b> <b>IM-240WNE,-23</b>				TITLE: <b>A.ICE CUBBER ASSY</b>				
INDEX NO.	DESCRIPTION	MATERIAL OR MODEL NUMBER	PART NUMBER	REQ'D NUMBER				
				A-1 B-1	B-2 B-3	B-4 F-0 (Note1)	F-0 (Note2) G-0	G-1
14	HINGE (RIGHT)		4H2583-01	1	1	1	1	1
15	HINGE (LEFT)		4H2584-01	1	1	1	1	1
16	HINGE SPACER (A)		4H0605-01	1	1	1	1	1
17	HINGE SPACER (B)		4H0605-02	1	1	1	1	1
18	HEX HEAD BOLT (SPRING WASHER AND FLAT WASHER)		FBK0616S0	4	4	4	4	4
19	SLOPE		3X4854G01	1	1	1	1	1
20	SPRING		4H0823-01	1	1	1	1	1
21	HOOK		4H2685-03	1	1	1	1	1
22	WIRING LABEL		3Y5103L01	1	-	-	-	-
			3Y6692L01		1	1	1	1
23	LABEL - GROUND		451712-01	1	-	-	-	-
	LABEL - GROUND (B)		450452-02	-	1	1	1	1
24	TRUSS HEAD MACHINE SCREW	(240NE,-21,-23)	FST0408S0	7	7	7	7	7
		(240WNE,-23)		7	8	8	8	8
25	WIRE SADDLE	(240NE,-21,-23)	428060-03	8	8	8	8	8
		(240WNE,-23)		9	9	9	9	9
26	CLAMP	(240NE,-21,-23)	427902-06	1	1	1	1	1
27	REAR PANEL		2X0296M01	1	1	1	1	1
28	INSULATION - PIPE		4Y2507-01	1	1	1	1	1
29	COVER - PIPE		390186M01	1	1	1	1	1
30	INSULATION - TOP PANEL		3X9100-01	1	1	1	1	1
31	TOP PANEL		1H4765M01	1	1	1	1	1
32	COVER - REAR	(240NE,-21,-23)	4Y7004M01	1	1	1	1	1
33	CONNECTOR		P00246-01	1	1	1	1	1
34	POWER SUPPLY CORD	EU-PLUG(16A)	P03362-01	1	1	1	1	1
		UK-PLUG(13A)	P03363-01	1	1	1	1	1
		AS-PLUG(15A)	P03364-01	1	1	1	1	1
35	BRACKET - CONT	(240WNE)	4Y7326M01	1	-	-	-	-
36	COVER - CONNECTOR		2X0271P01	1	1	1	1	1
37	NAME PLATE		N/A	1	1	1	1	1
38	SPRING WASHER		FWSP04S0	2	3	3	3	3
39	STARTING DEVICE		P01856-01	-	1	1	1	1
40	S-TITE TRUSS HEAD SCREW		FTS0408M0	1	1	1	1	1
41	LABEL-CONNECTION	(240WNE,-23)	464541-01	1	1	1	1	1

\*Note1 : From F00001 to F01133

\*Note2 : From F01134

MODEL: <b>IM-240NE,-21,-23</b> <b>IM-240WNE,-23</b>			TITLE: <b>A.ICE CUBBER ASSY</b>					
INDEX NO.	DESCRIPTION	MATERIAL OR MODEL NUMBER	PART NUMBER	REQ'D NUMBER				
				G-2 J-0	J-1	J-2 K-0	K-1	
B	REFRIGERATION ASSY	(240NE)	1H5213A01	-	-	-	-	
			1H5977A01	1	1	1	1	
		(240NE-21)	1H5213A01	1	1	1	-	
			1H5977A01	-	-	-	1	
		(240NE-23)	1H5213A01	1	1	-	-	
			1H5977A01	-	-	1	1	
		(240WNE)	1H5216A01	-	-	-	-	
			1H5978A01	1	1	1	1	
(240WNE-23)	1H5216A01	1	1	-	-			
	1H5978A01	-	-	1	1			
C	MECHANISM ASSY		1H4762A01	1	1	1	1	
D	CONTROL BOX ASSY	(240NE)	2X1197A01	-	-	-	-	
			2X3379A01	1	-	-	-	
			2X3379A03	-	1	1	1	
		(240NE-21)	2X1197A01	1	1	1	-	
			2X3379A03	-	-	-	1	
		(240NE-23)	2X1197A01	1	1	-	-	
			2X3379A03	-	-	1	1	
		(240WNE)	2X1197A02	-	-	-	-	
			2X3379A02	1	-	-	-	
		(240WNE-23)	2X3379A04	-	1	1	1	
2X1197A02	1		1	-	-			
			2X3379A04	-	-	1	1	
E	WATER CIRCUIT ASSY		2X0293A01	1	1	1	1	
F	DOOR ASSY		3Y5436A01	1	1	1	1	
G	FRONT COVER UPPER ASSY		3Y5438A01	1	1	1	1	
		(GRAM)	3Y5438A02	1	1	1	1	
H	FRONTCOVER(LOWER) ASSY	(240NE,-21,-23)	2X1261A01	1	1	1	1	
		(240WNE,-23)	3Y6776A01	1	1	1	1	
M	ACCESSORIES			1	1	1	1	
1	BODY		1H4759G01	1	1	1	1	
2	FRONT FRAME		3X9103-01	1	1	1	1	
3	RIVET		7170-0002	8	8	8	8	
4	INSULATION - FRONT FRAME		4Y6991P01	1	1	1	1	
5	TAPER COLLAR		4H0171-01	4	4	4	4	
6	TAPPING SCREW - HEX		442040-01	4	4	4	4	



MODEL: <b>IM-240NE,-21,-23</b> <b>IM-240WNE,-23</b>				TITLE: <b>A.ICE CUBBER ASSY</b>				
INDEX NO.	DESCRIPTION	MATERIAL OR MODEL NUMBER	PART NUMBER	REQ'D NUMBER				
				G-2 J-0	J-1	J-2 K-0	K-1	
7	FLANGE BOLT (C-TITE)	(240NE,-21,-23)	FTR0408M0	34	34	34	34	
		(240WNE,-23)		32	32	32	32	
10	ICE GUIDE G		4Y7002G01	1	1	1	1	
11	DRAIN PAN		3Y5434G01	1	1	1	1	
12	DRAIN PIPE		4X7117-02	1	1	1	1	
13	DRAIN TUBE		4H2585-01	1	1	1	1	
14	HINGE (RIGHT)		4H2583-01	1	1	1	1	
15	HINGE (LEFT)		4H2584-01	1	1	1	1	
16	HINGE SPACER (A)		4H0605-01	1	1	1	1	
17	HINGE SPACER (B)		4H0605-02	1	1	1	1	
18	HEX HEAD BOLT (SPRING WASHER AND FLAT WASHER)		FBK0616S0	4	4	4	4	
19	SLOPE		3X4854G01	1	1	1	1	
20	SPRING		4H0823-01	1	1	1	1	
21	HOOK		4H2685-03	1	1	1	1	
22	WIRING LABEL		3Y6692L01	1	1	1	1	
23	LABEL - GROUND (B)		450452-02	1	1	1	1	
24	TRUSS HEAD MACHINE SCREW	(240NE,-21,-23)	FST0408S0	7	7	7	7	
		(240WNE,-23)		8	8	8	8	
25	WIRE SADDLE	(240NE,-21,-23)	428060-03	8	8	8	8	
		(240WNE,-23)		9	9	9	9	
26	CLAMP	(240NE,-21,-23)	427902-06	1	1	1	1	
27	REAR PANEL		2X0296M01	1	1	1	1	
28	INSULATION - PIPE		4Y2507-01	1	1	1	1	
29	COVER - PIPE		390186M01	1	1	1	1	
30	INSULATION - TOP PANEL		3X9100-01	1	1	1	1	
31	TOP PANEL		1H4765M01	1	1	1	1	
32	COVER - REAR	(240NE,-21,-23)	4Y7004M01	1	1	1	1	
33	CONNECTOR		P00246-01	1	1	1	1	
34	POWER SUPPLY CORD	EU-PLUG(16A)	P03362-01	1	1	1	1	
		UK-PLUG(13A)	P03363-01	1	1	1	1	
		AS-PLUG(15A)	P03364-01	1	1	1	1	
36	COVER - CONNECTOR		2X0271P01	1	1	1	1	
37	NAME PLATE		N/A	1	1	1	1	
38	SPRING WASHER		FWSP04S0	3	3	3	3	
39	STARTING DEVICE		P01856-01	1	1	1	1	
40	S-TITE TRUSS HEAD SCREW		FTS0408M0	1	1	1	1	

MODEL: <b>IM-240NE,-21,-23</b> <b>IM-240WNE,-23</b>				TITLE: <b>A.ICE CUBBER ASSY</b>				
INDEX NO.	DESCRIPTION	MATERIAL OR MODEL NUMBER	PART NUMBER	REQ'D NUMBER				
				G-2 J-0	J-1	J-2 K-0	K-1	
41	LABEL-CONNECTION	(240WNE,-23)	464541-01	1	1	1	1	



**PLATON SERVICE**

8 (800) 500-34-41

www.platonservice.com

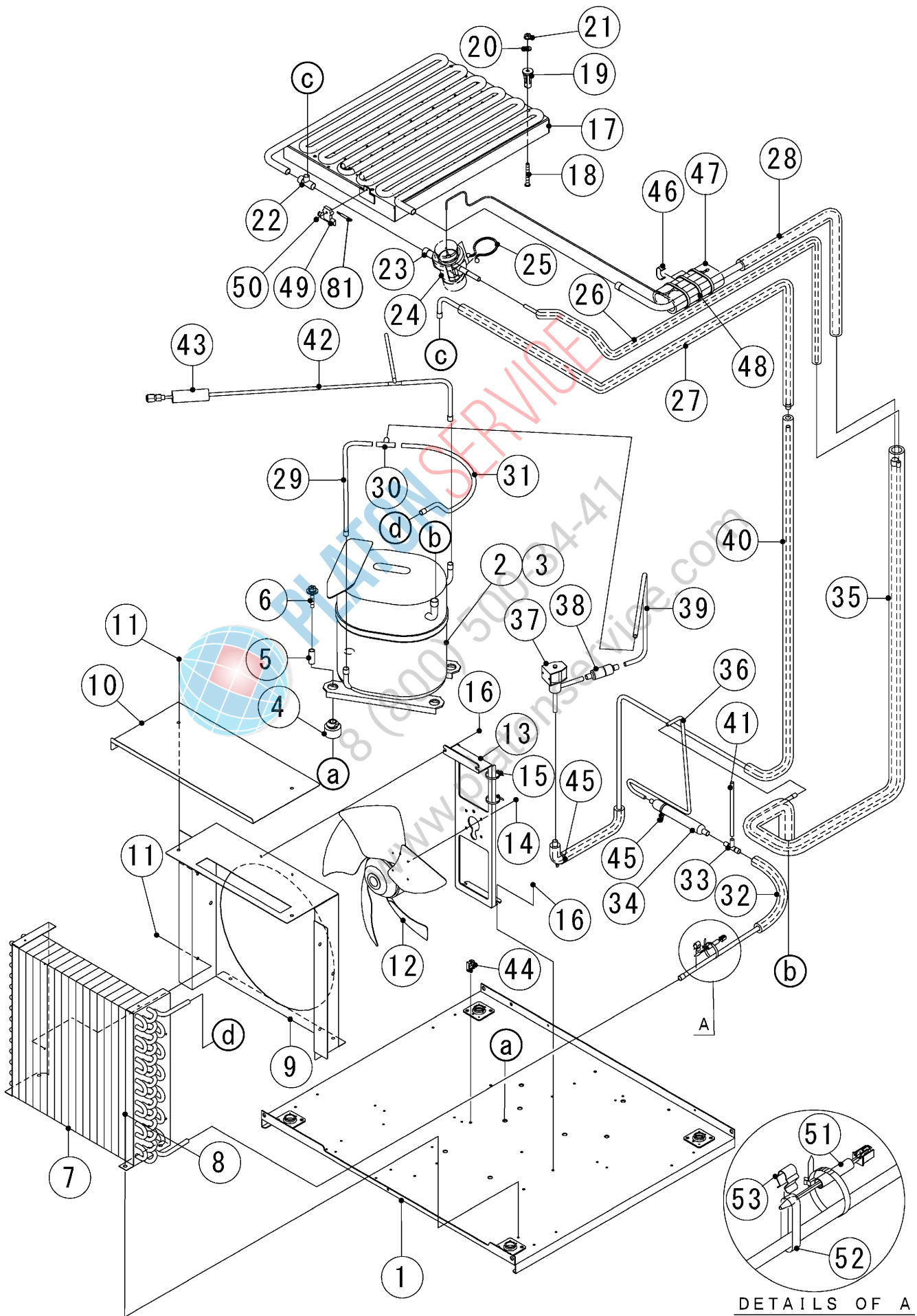

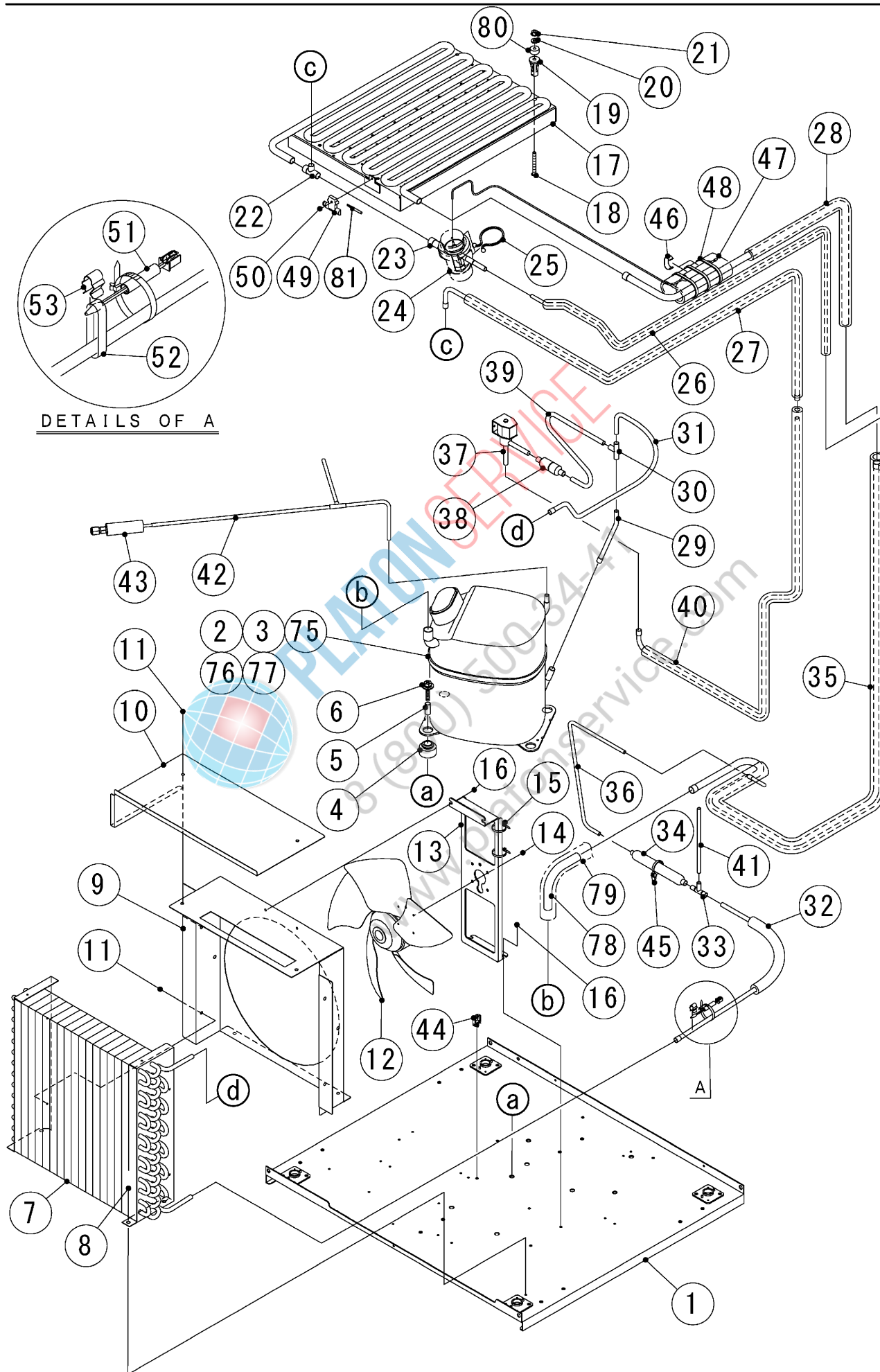

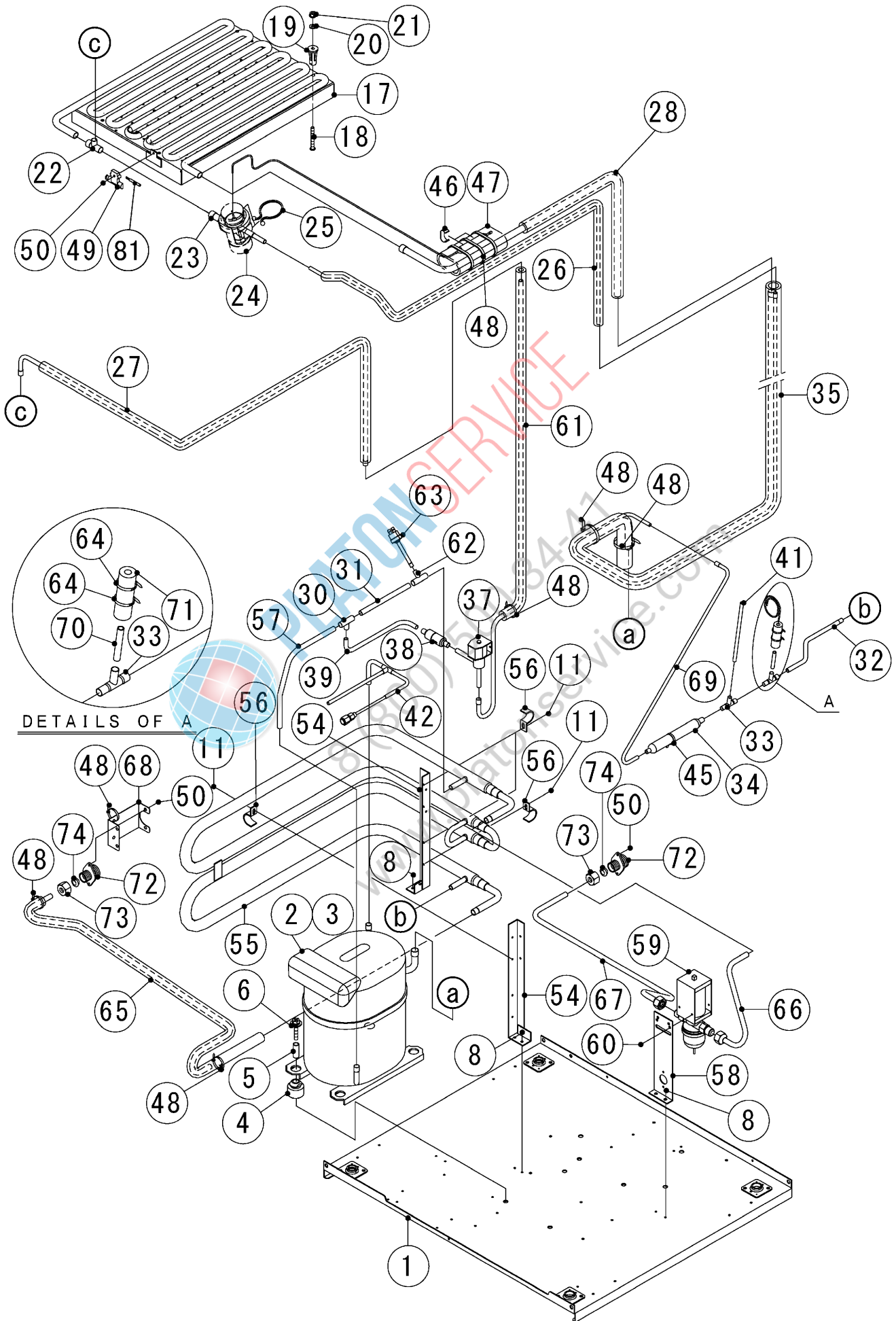

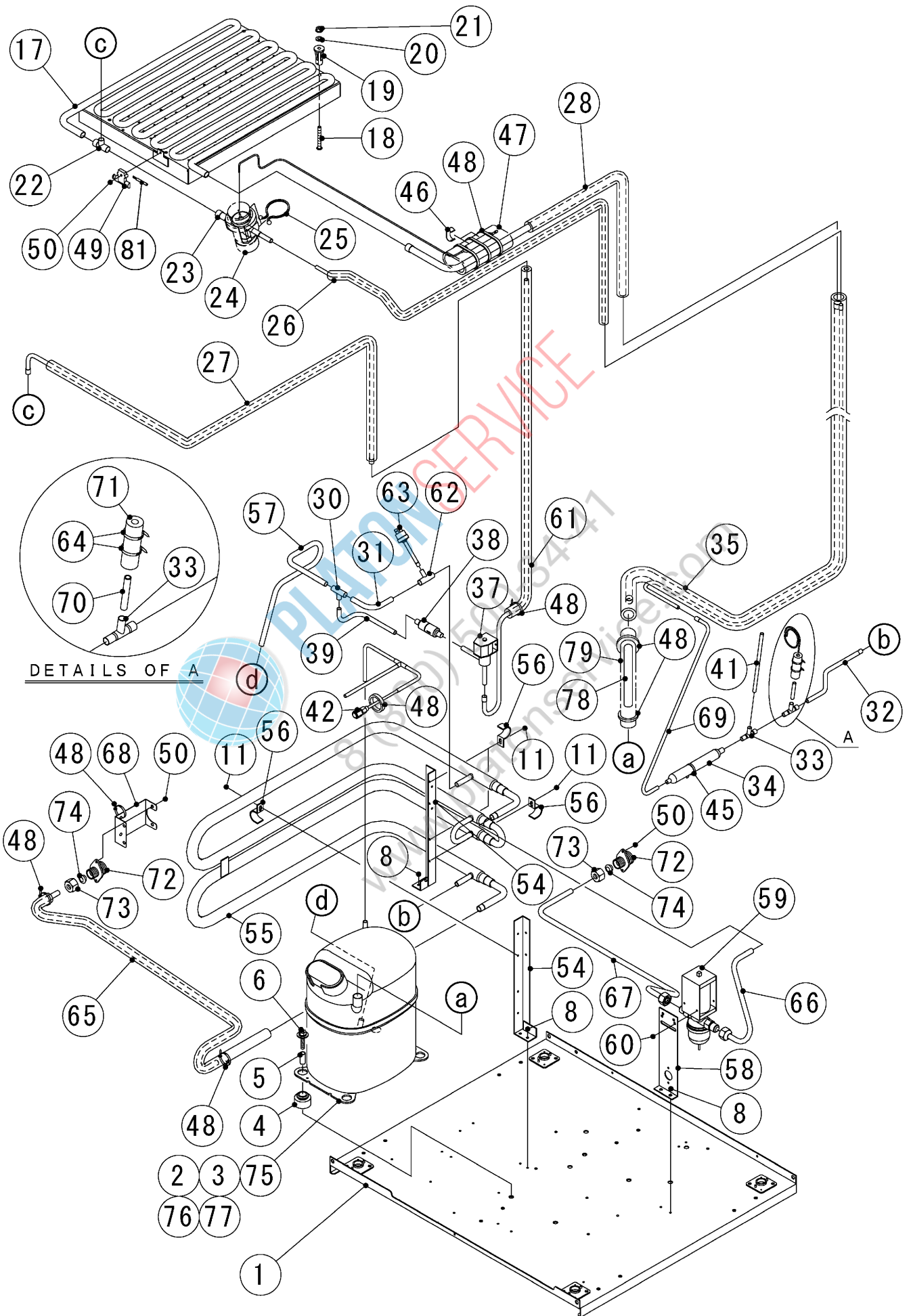

MODEL: <b>IM-240NE,-21,-23</b> <b>IM-240WNE,-23</b>				TITLE: <b>B.REFRIGERATION ASSY</b>					
INDEX NO.	DESCRIPTION	MATERIAL OR MODEL NUMBER	PART NUMBER	REQ'D NUMBER					
				A-1 B-1	B-2 B-3	B-4 F-0 (Note1)	F-0 (Note2) G-0	G-1	
1	BASE	(240NE,-21,-23)	3Y5423G01	1	-	-	-	-	
			3Y6768G01	-	1	1	1	1	
		(240WNE,-23)	3Y5539G01	1	-	-	-	-	
			3Y6772G01	-	1	1	1	1	
2	COMPRESSOR		4A1581-01	1	-	-	-	-	
			P01855-01	-	1	1	1	1	
3	MOTOR PROTECTOR		4A1581F01	1	1	1	1	1	
4	GROMMET		434922-02	4	-	-	-	-	
	RUBBER GROMMET		P01858-01	-	4	4	4	4	
5	SPACER		434921-01	4	-	-	-	-	
	SLEEVE		P01859-01	-	4	4	4	4	
6	BOLT		436206-04	4	-	-	-	-	
			436206-03	-	4	4	4	4	
7	CONDENSER	(240NE,-21,-23)	P03307-01	1	1	1	1	1	
8	FLANGE BOLT (C-TITE)	(240NE,-21,-23)	FTR0408M0	2	2	2	2	2	
		(240WNE,-23)		6	6	6	6	6	
9	SHROUD	(240NE,-21,-23)	2H9947M01	1	1	1	1	1	
10	PLATE - COND	(240NE,-21,-23)	4Y6996M01	1	-	-	-	-	
			4Y7848M01	-	1	1	1	1	
11	TRUSS HEAD TAPPING SCREW T2	(240NE,-21,-23)	FT20408F0	6	6	6	6	6	
		(240WNE,-23)		4	4	4	4	4	
12	FAN MOTOR	(240NE,-21,-23)	P02545-01	1	1	1	1	1	
13	BRACKET - FM	(240NE,-21,-23)	3Y5075M01	1	1	1	1	1	
14	HEX HEAD BOLT (SPRING WASHER AND FLAT WASHER)	(240NE,-21,-23)	FBK0408F0	5	5	5	5	5	
15	TIE	(240NE,-21,-23)	7920-0002	2	2	2	2	2	
16	HEX HEAD BOLT (SPRING WASHER AND FLAT WASHER)	(240NE,-21,-23)	FBK0510F0	4	4	4	4	4	
17	EVAPORATOR		2H7526G02	1	1	1	1	1	
			(240NE-21)	208205G04	-	1	1	1	1
			(240NE-23)(240WNE-23)	2H1833G03	1	1	1	1	1
18	SCREW EVAPORATOR		4Y4922M02	4	4	4	4	4	
			(240NE-21,-23)(240WNE-23)	4Y4922M03	4	4	4	4	4
19	COLLAR		3H3879-01	4	4	4	4	4	
20	WASHER		4H0777-01	4	4	4	4	4	
21	FLANGE NUT		FNHF06S0	4	4	4	4	4	
22	TEE		430608-01	1	1	1	1	1	
23	EXPANSION VALVE		P01874-01	1	1	1	1	1	

MODEL: <b>IM-240NE,-21,-23</b> <b>IM-240WNE,-23</b>				TITLE: <b>B.REFRIGERATION ASSY</b>				
INDEX NO.	DESCRIPTION	MATERIAL OR MODEL NUMBER	PART NUMBER	REQ'D NUMBER				
				A-1 B-1	B-2 B-3	B-4 F-0 (Note1)	F-0 (Note2) G-0	G-1
24	VALVE COVER		3Y3051P01	1	1	1	1	1
25	CLAMP		P00752-01	2	2	2	2	2
26	COPPER TUBE(D) - HIGH SIDE		3Y5424G01	1	1	1	1	1
27	COPPER TUBE(C) - HOT GAS		3Y5425G01	1	1	1	1	1
28	COPPER TUBE(A) - LOW SIDE		3Y5426G01	1	1	1	1	1
29	COPPER TUBE(A) - HIGH SIDE	(240NE,-21,-23)	4Y6992M01	1	-	-	-	-
			4Y7844M01	-	1	1	1	1
30	TEE	(240NE,-21,-23)	420041-11	1	1	1	1	1
		(240WNE,-23)	420041-09	1	1	1	1	1
31	COPPER TUBE(A-2) - HIGH SIDE	(240NE,-21,-23)	4Y6993M01	1	-	-	-	-
			4Y7843M01	-	1	1	1	1
		(240WNE,-23)	4Y7079M01	1	-	-	-	-
			4Y7834M01	-	1	1	1	1
32	COPPER TUBE(B) - HIGH SIDE	(240NE,-21,-23)	4Y6994G01	1	-	-	-	-
			4Y7845G01	-	1	1	1	1
		(240WNE,-23)	4Y7080M01	1	1	1	1	1
33	TEE	(240NE,-21,-23)	4Y4060Z01	1	1	1	1	1
		(240WNE,-23)		2	2	2	2	2
34	DRIER		458776-01	1	1	1	1	1
35	HEAT EXCHANGER	(240NE,-21,-23)	2X0289G01	1	-	-	-	-
			2X1258G01	-	1	1	1	1
		(240WNE,-23)	2X0364G01	1	-	-	-	-
			2X1267G01	-	1	1	1	1
36	COPPER TUBE(B2) - HIGH SIDE	(240NE,-21,-23)	4Y7057M01	1	-	-	-	-
			4Y7846M01	-	1	1	1	1
37	HOT GAS VALVE		P04242-01	1	1	1	1	1
38	STRAINER		P00812-01	1	1	1	1	1
39	COPPER TUBE(A) - HOT GAS	(240NE,-21,-23)	3Y5427M01	1	-	-	-	-
			4Y7847M01	-	1	1	1	1
		(240WNE,-23)	4Y7082M01	1	-	-	-	-
			4Y7835M01	-	1	1	1	1
40	COPPER TUBE(B) - HOT GAS	(240NE,-21,-23)	2X0290G01	1	-	-	-	-
			2X1259G01	-	1	1	1	1
41	PROCESS TUBE		4Y0273-01	1	1	1	1	1
42	COPPER TUBE(G) - PROCESS	(240NE,-21,-23)	3Y5508G01	1	-	-	-	-
			3Y6767G01	-	1	1	1	1
		(240WNE,-23)	3Y5534G01	1	-	-	-	-
			3Y6759G01	-	1	1	1	1



MODEL: <b>IM-240NE,-21,-23</b> <b>IM-240WNE,-23</b>				TITLE: <b>B.REFRIGERATION ASSY</b>				
INDEX NO.	DESCRIPTION	MATERIAL OR MODEL NUMBER	PART NUMBER	REQ'D NUMBER				
				A-1 B-1	B-2 B-3	B-4 F-0 (Note1)	F-0 (Note2) G-0	G-1
43	INSULATION TUBE	(240NE,-21,-23)	H71323070	1	1	1	1	1
44	WIRE SADDLE	(240NE,-21,-23)	428060-03	1	1	1	1	1
45	TIE	(240NE,-21,-23)	457167-01	2	-	-	-	-
				-	1	1	1	1
		(240WNE,-23)		1	1	1	1	1
46	CLIP		452254-02	2	2	2	2	2
47	INSULATION		4X8643-01	1	1	1	1	1
48	TIE	(240NE,-21,-23)	7920-0003	3	3	3	3	3
		(240WNE,-23)		9	-	-	-	-
				-	10	10	10	10
49	HOLDER - THERMISTOR		315479-01	1	1	1	1	1
50	TRUSS HEAD TAPPING SCREW	(240NE,-21,-23)	FTS0408M0	1	1	1	1	1
	(S-TITE)	(240WNE,-23)		5	5	5	5	5
51	THERMISTOR(G) - FILTER	(240NE,-21,-23)	4Y4859G01	1	1	1	1	1
52	ALUMINUM TAPE	(240NE,-21,-23)	1H4761-01	1	-	-	-	-
			1H5213Z01	-	1	1	1	1
53	CLIP - THERMISTOR	(240NE,-21,-23)	4R2938-01	1	1	1	1	1
54	BRACKET CONDENSER	(240WNE,-23)	425490-01	2	2	2	2	2
55	CONDENSER - WATER COOLED	(240WNE,-23)	103099G01	1	1	1	1	1
56	CLAMP(B) - CONDENSER	(240WNE,-23)	4H0622-01	4	4	4	4	4
57	PIPE(A-1) - HIGH SIDE	(240WNE,-23)	3Y5531M01	1	-	-	-	-
			4Y7836M01	-	1	1	1	1
58	BRACKET - WATER REGURATOR	(240WNE,-23)	4X5632-01	1	1	1	1	1
59	WATER REGULATOR	(240WNE,-23)	P04025-01	1	1	1	1	1
60	TRUSS HEAD MACHINE SCREW	(240WNE,-23)	FST0408S0	2	2	2	2	2
61	COPPER TUBE (B) - HOT GAS	(240WNE,-23)	2X0365G01	1	1	1	1	1
62	TEE	(240WNE,-23)	420041-05	1	1	1	1	1
63	PRESSURE SWITCH	(240WNE,-23)	459863-03	1	1	1	1	1
64	NYLON TIE	(240WNE,-23)	7920-0002	2	2	2	2	2
65	COPPER TUBE(A) - WATER	(240WNE,-23)	3Y5540G01	1	1	1	1	1
66	COPPER TUBE (B) - WATER	(240WNE,-23)	3Y5541G01	1	1	1	1	1
67	COPPER TUBE (C) - WATER	(240WNE,-23)	3Y5542G01	1	1	1	1	1
68	BRACKET - WATER PIPE	(240WNE,-23)	4Y7086M01	1	1	1	1	1
69	COPPER TUBE(C) - HIGH SIDE	(240WNE,-23)	4Y7081M01	1	-	-	-	-
			4Y7850M01	-	1	1	1	1
70	TUBE - CAPILLARY	(240WNE,-23)	4X4276-01	1	1	1	1	1
71	INSULATION - CAP	(240WNE,-23)	4H9594-01	1	1	1	1	1
72	FITTING(P)	(240WNE,-23)	3Y0747-01	2	2	2	2	2

MODEL: <b>IM-240NE,-21,-23</b> <b>IM-240WNE,-23</b>			TITLE: <b>B.REFRIGERATION ASSY</b>					
INDEX NO.	DESCRIPTION	MATERIAL OR MODEL NUMBER	PART NUMBER	REQ'D NUMBER				
				A-1 B-1	B-2 B-3	B-4 F-0 (Note1)	F-0 (Note2) G-0	G-1
73	NUT (A) - FITTING	(240WNE,-23)	415713-03	2	2	2	2	2
74	TAPPERED PACKING	(240WNE,-23)	415715-01	2	2	2	2	2
75	COVER		P01857-01	-	1	1	1	1
76	CLAMP		P01862-01	-	1	1	1	1
77	GASKET		P01863-01	-	1	1	1	1
78	COPPER TUBE(D)-LOW SIDE		4Y7817M01	-	1	1	1	1
79	INSULATION TUBE	(240NE,-21,-23)	H72030400	-	1	1	1	1
		(240WNE,-23)	H72030250	-	1	1	1	1
80	WASHER	(240NE-21)	4H1365-06	-	4	4	4	4
		(240NE-23)(240WNE-23)	4H1365-05	4	4	4	4	4
81	THERMISTOR-CUBE CONTROL		P00350-04	-	1	1	1	1

\*Note1 : From F00001 to F01133

\*Note2 : From F01134



**PLATON SERVICE**  
 8 (800) 500-34-41  
 www.platonservice.com

MODEL: <b>IM-240NE,-21,-23</b> <b>IM-240WNE,-23</b>				TITLE: <b>B.REFRIGERATION ASSY</b>				
INDEX NO.	DESCRIPTION	MATERIAL OR MODEL NUMBER	PART NUMBER	REQ'D NUMBER				
				G-2 J-0	J-1	J-2 K-0	K-1	
1	BASE	(240NE,-21,-23)	3Y6768G01	1	1	1	1	
		(240WNE,-23)	3Y6772G01	1	1	1	1	
2	COMPRESSOR		P01855-01	1	1	1	1	
3	MOTOR PROTECTOR		4A1581F01	1	1	1	1	
4	RUBBER GROMMET		P01858-01	4	4	4	4	
5	SLEEVE		P01859-01	4	4	4	4	
6	BOLT		436206-03	4	4	4	4	
7	CONDENSER	(240NE,-21,-23)	P03307-01	1	1	1	1	
8	FLANGE BOLT (C-TITE)	(240NE,-21,-23)	FTR0408M0	2	2	2	2	
		(240WNE,-23)		6	6	6	6	
9	SHROUD	(240NE,-21,-23)	2H9947M01	1	1	1	1	
10	PLATE - COND	(240NE,-21,-23)	4Y7848M01	1	1	1	1	
11	TRUSS HEAD TAPPING SCREW T2	(240NE,-21,-23)	FT20408F0	6	6	6	6	
		(240WNE,-23)		4	4	4	4	
12	FAN MOTOR	(240NE,-21,-23)	P02545-01	1	1	1	1	
13	BRACKET - FM	(240NE,-21,-23)	3Y5075M01	1	1	1	1	
14	HEX HEAD BOLT	(240NE,-21,-23)	FBK0408F0	5	5	5	5	
	(SPRING WASHER AND FLAT WASHER)							
15	TIE	(240NE,-21,-23)	7920-0002	2	2	2	2	
16	HEX HEAD BOLT	(240NE,-21,-23)	FBK0510F0	4	4	4	4	
	(SPRING WASHER AND FLAT WASHER)							
17	EVAPORATOR	(240NE-21)	2H7526G02	-	-	-	-	
			2X2459G01	1	1	1	1	
			208205G04	1	1	1	-	
			2X2532G01	-	-	-	1	
			2H1833G03	1	1	-	-	
			(240NE-23)(240WNE-23)	2X2594G01	-	-	1	1
18	SCREW EVAPORATOR	(240NE-21,-23)(240WNE-23)	4Y4922M02	4	4	4	4	
			4Y4922M03	4	4	4	4	
19	COLLAR		3H3879-01	4	4	4	4	
20	WASHER		4H0777-01	4	4	4	4	
21	FLANGE NUT		FNHF06S0	4	4	4	4	
22	TEE		430608-01	1	1	1	1	
23	EXPANSION VALVE		P01874-01	1	1	1	1	
24	VALVE COVER		3Y3051P01	1	1	1	1	
25	CLAMP		P00752-01	2	2	2	2	
26	COPPER TUBE(D) - HIGH SIDE		3Y5424G01	1	1	1	1	
27	COPPER TUBE(C) - HOT GAS		3Y5425G01	1	1	1	1	

MODEL: <b>IM-240NE,-21,-23</b> <b>IM-240WNE,-23</b>				TITLE: <b>B.REFRIGERATION ASSY</b>				
INDEX NO.	DESCRIPTION	MATERIAL OR MODEL NUMBER	PART NUMBER	REQ'D NUMBER				
				G-2 J-0	J-1	J-2 K-0	K-1	
28	COPPER TUBE(A) - LOW SIDE		3Y5426G01	1	1	1	1	
29	COPPER TUBE(A) - HIGH SIDE	(240NE,-21,-23)	4Y7844M01	1	1	1	1	
30	TEE	(240NE,-21,-23)	420041-11	1	1	1	1	
		(240WNE,-23)	420041-09	1	1	1	1	
31	COPPER TUBE(A-2) - HIGH SIDE	(240NE,-21,-23)	4Y7843M01	1	1	1	1	
		(240WNE,-23)	4Y7834M01	1	1	1	1	
32	COPPER TUBE(B) - HIGH SIDE	(240NE,-21,-23)	4Y7845G01	1	1	1	1	
		(240WNE,-23)	4Y7080M01	1	1	1	1	
33	TEE	(240NE,-21,-23)	4Y4060Z01	1	1	1	1	
		(240WNE,-23)		2	2	2	2	
34	DRIER		458776-01	1	1	1	1	
35	HEAT EXCHANGER	(240NE,-21,-23)	2X1258G01	1	1	1	1	
		(240WNE,-23)	2X1267G01	1	1	1	1	
36	COPPER TUBE(B2) - HIGH SIDE	(240NE,-21,-23)	4Y7846M01	1	1	1	1	
37	HOT GAS VALVE		P04242-01	1	1	1	1	
38	STRAINER		P00812-01	1	1	1	1	
39	COPPER TUBE(A) - HOT GAS	(240NE,-21,-23)	4Y7847M01	1	1	1	1	
		(240WNE,-23)	4Y7835M01	1	1	1	1	
40	COPPER TUBE(B) - HOT GAS	(240NE,-21,-23)	2X1259G01	1	1	1	1	
41	PROCESS TUBE		4Y0273-01	1	1	1	1	
42	COPPER TUBE(G) - PROCESS	(240NE,-21,-23)	3Y6767G01	1	1	1	1	
		(240WNE,-23)	3Y6759G01	1	1	1	1	
43	INSULATION TUBE	(240NE,-21,-23)	H71323070	1	1	1	1	
44	WIRE SADDLE	(240NE,-21,-23)	428060-03	1	1	1	1	
45	TIE		457167-01	1	1	1	1	
46	CLIP		452254-02	2	2	2	2	
47	INSULATION		4X8643-01	1	1	1	1	
48	TIE	(240NE,-21,-23)	7920-0003	3	3	3	3	
		(240WNE,-23)		10	10	10	10	
49	HOLDER - THERMISTOR		315479-01	1	1	1	1	
50	TRUSS HEAD TAPPING SCREW (S-TITE)	(240NE,-21,-23)	FTS0408M0	1	1	1	1	
		(240WNE,-23)		5	5	5	5	
51	THERMISTOR(G) - FILTER	(240NE,-21,-23)	4Y4859G01	1	1	1	1	
52	ALUMINUM TAPE	(240NE,-21,-23)	1H5213Z01	1	1	1	1	
53	CLIP - THERMISTOR	(240NE,-21,-23)	4R2938-01	1	1	1	1	
54	BRACKET CONDENSER	(240WNE,-23)	425490-01	2	2	2	2	
55	CONDENSER - WATER COOLED	(240WNE,-23)	103099G01	1	1	1	1	
56	CLAMP(B) - CONDENSER	(240WNE,-23)	4H0622-01	4	4	4	4	



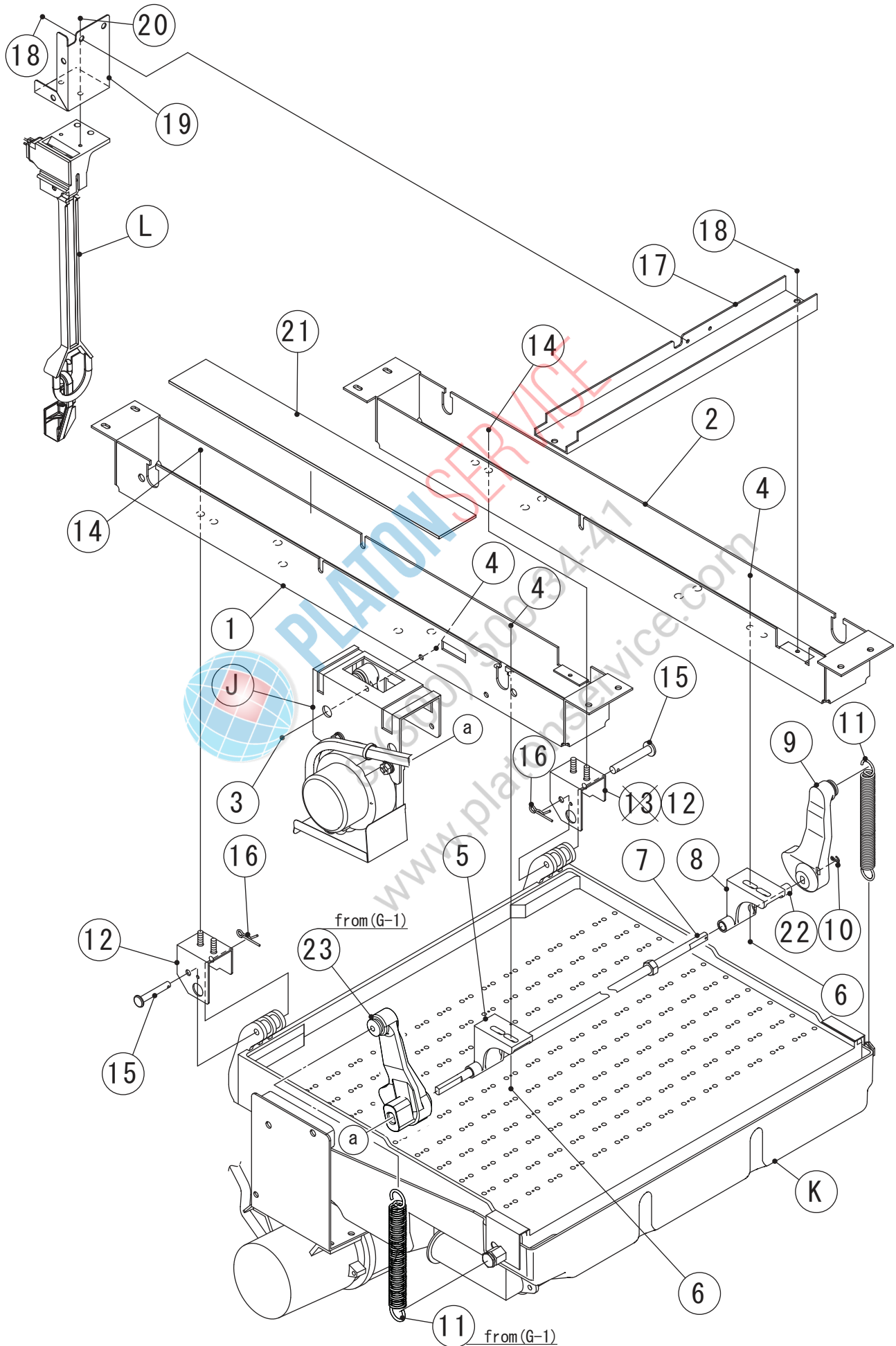

MODEL: <b>IM-240NE,-21,-23</b> <b>IM-240WNE,-23</b>			TITLE: <b>C.MECHANISM ASSY</b>					
INDEX NO.	DESCRIPTION	MATERIAL OR MODEL NUMBER	PART NUMBER	REQ'D NUMBER				
				A-1 B-1	B-2 B-3	B-4 F-0 (Note1)	F-0 (Note2) G-0	G-1
J	ACTUATOR MOTOR ASSY		3Y8847A01	1	1	1	1	-
			3Y9860A01	-	-	-	-	1
K	WATER PAN ASSY		1H4689A01	1	1	1	1	1
L	BIN SWITCH AY		3Y5430A01	1	1	1	1	1
1	FRAME - FRONT	*Note1	3Y5428M02	1	1	1	-	-
		*Note2	3Y5428M01	-	-	-	1	1
2	FRAME - REAR	*Note1	3Y5429M02	1	1	1	-	-
		*Note2	3Y5429M01	-	-	-	1	1
3	TRUSS HEAD MACHINE SCREW		FST0512S0	2	2	2	2	2
4	FLANGE NUT		FNHF05S0	6	6	6	6	6
5	BEARING - CAM SHAFT		3X8307-02	1	1	1	1	1
6	TRUSS HEAD MACHINE SCREW		FST0516S0	4	4	4	4	-
	HEX HEAD BOLT (SPRING WASHER AND FLAT WASHER)		FBK0516S0	-	-	-	-	4
7	CAM SHAFT		425511G02	1	1	1	1	1
8	BEARING - CAM SHAFT		3X8307-02	1	1	1	1	1
9	CAM (B)		376546P01	1	1	1	1	1
10	COTTER PIN		711S-0212	1	1	1	1	1
11	EXTEN SPRING		4H3473-01	1	1	1	1	2
12	BEARING PLATE		3H1440G03	2	2	2	2	2
13	BEARING PLATE		3H1440G04	-	-	-	-	-
14	FLANGE NUT		FNHF06S0	4	4	4	4	4
15	SHAFT (B)		4H1184-02	2	2	2	2	2
16	SNAP PIN		715S-0006	2	2	2	2	2
17	FRAME - BIN SW	*Note1	4Y6997M02	1	1	1	-	-
		*Note2	4Y6997M01	-	-	-	1	1
18	FLANGE BOLT		FBF0410M0	4	4	4	4	4
19	BRACKET - BIN SW		4Y6998M01	1	1	1	1	1
20	TRUSS HEAD TAPPING SCREW T2		FT20410M0	2	2	2	2	2
21	INSULATION - MECHA		4Z0766P01	1	1	1	1	1
22	COLLAR	(240NE-21)	429124-01	-	1	1	1	1
23	CAM(A)		306543G04	-	-	-	-	1

\*Note1 : From F00001 to F01133

\*Note2 : From F01134





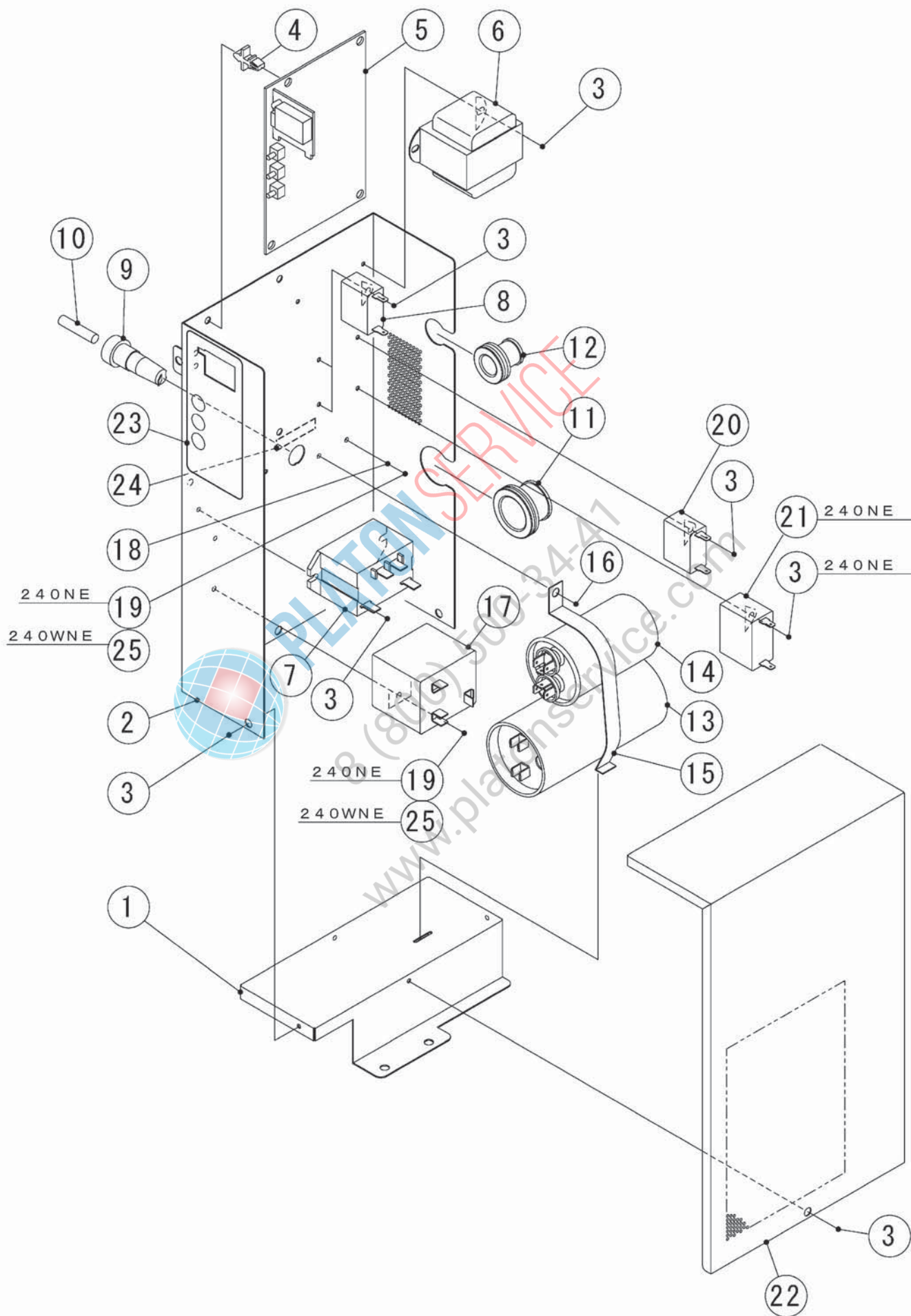

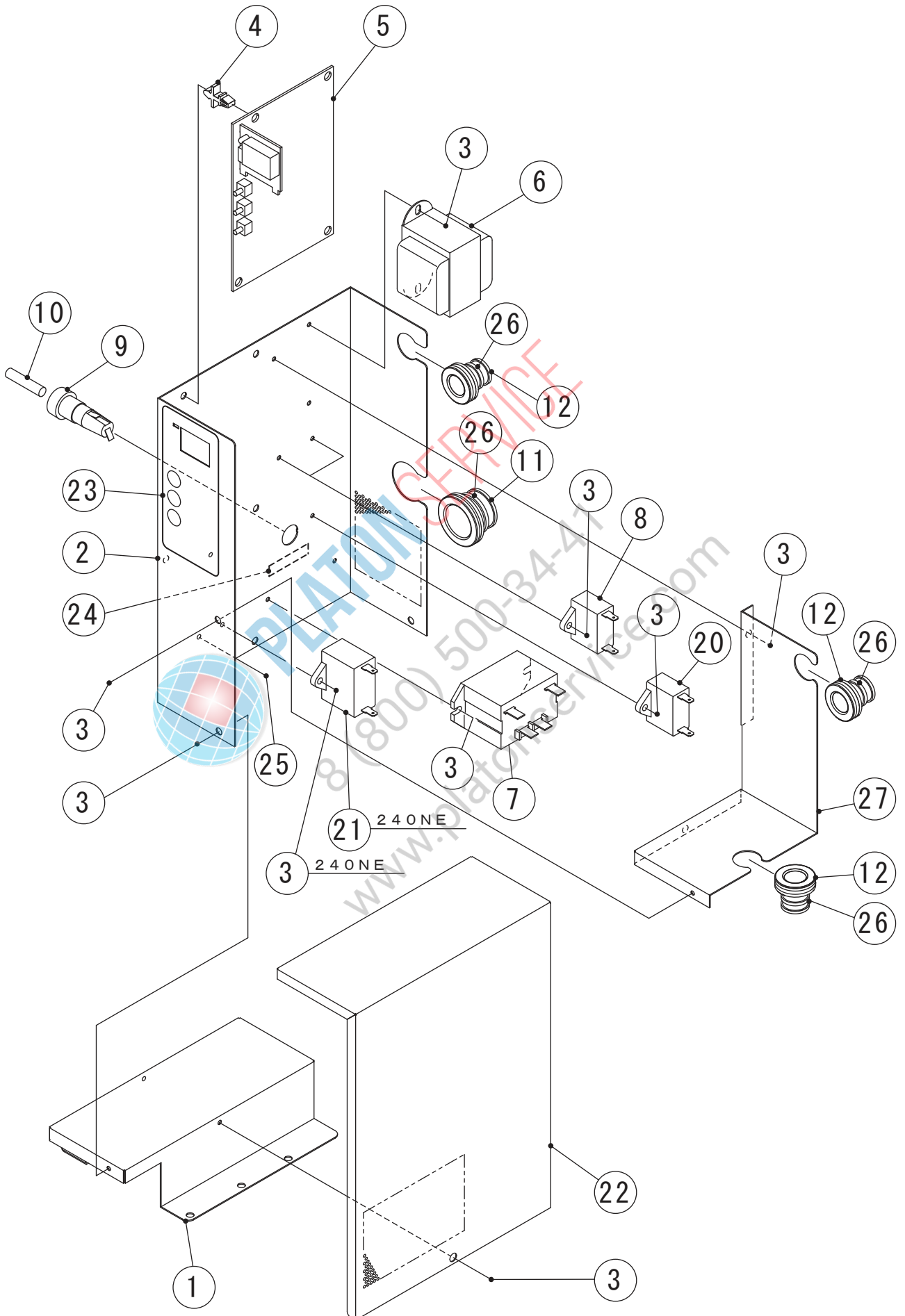

MODEL: <b>IM-240NE,-21,-23</b> <b>IM-240WNE,-23</b>			TITLE: <b>D.CONTROL BOX ASSY</b>					
INDEX NO.	DESCRIPTION	MATERIAL OR MODEL NUMBER	PART NUMBER	REQ'D NUMBER				
				A-1 B-1	B-2 B-3	B-4 F-0 (Note1)	F-0 (Note2) G-0	G-1
1	CONTROL BOX B		3Y5431M01	1	-	-	-	-
	CONTROLBOX - BASE		3Y6722M01	-	1	1	1	1
2	CONTROL BOX - BODY G		3Y5432G01	1	-	-	-	-
	CONTROL BOX(B)		2X1053M01	-	1	-	-	-
			2X1251M01	-	-	1	1	1
3	TRUSS HEAD TAPPING SCREW T2	(240NE,-21,-23)	FT20410F0	12	15	15	15	15
		(240WNE,-23)		11	14	14	14	14
4	BOARD SUPPORT		P04204-01	4	4	4	4	4
5	CONTROLLER BOARD		P01873-01	1	1	1	1	1
6	TRANSFORMER		P02714-01	1	1	1	1	1
7	POWER RELAY		P00034-01	1	1	1	1	1
8	CAPACITOR		P01870-01	2	2	2	2	2
9	FUSE HOLDER		P00014-01	1	1	-	-	-
			P02829-01	-	-	1	1	1
10	FUSE		P01876-01	1	1	-	-	-
			P04203-01	-	-	1	1	1
11	GROMMET		4H2568-01	1	1	1	1	1
12	GROMMET		4H2568-02	1	3	3	3	3
13	START CAPACITOR	3535B7C0064A250A5	3A0076-14	1	-	-	-	-
14	CAPACITOR - RUN		3A2005-01	1	-	-	-	-
15	BAND		427254-01	1	-	-	-	-
16	FLANGE BOLT (C-TITE)		FTR0408M0	1	-	-	-	-
17	STARTER		4A1107-02	1	-	-	-	-
18	SPRING WASHER		FWSP04S0	1	-	-	-	-
19	TRUSS HEAD TAPPING SCREW	(240NE,-23)	FTS0408M0	2	-	-	-	-
	(S-TITE)							
20	CAPACITOR		P01910-01	1	1	1	1	1
21	CAPACITOR	(240NE,-21,-23)	P01865-01	1	1	1	1	1
22	CONTROL BOX - COVER		3Y5371M01	1	-	-	-	-
	CONTROL BOX COVER		3Y6513M01	-	1	1	1	1
23	CONTROL LABEL		475642L01	1	1	1	1	1
24	LABEL - FUSE		466798-01	1	1	1	1	1
25	TRUSS HEAD MACHINE SCREW		FST0408S0	2	1	1	1	1
26	TIE		7920-0003	-	4	4	4	4
27	SEPARATOR - BOX		3Y6512M01	-	1	1	1	1

\*Note1 : From F00001 to F01133

\*Note2 : From F01134

MODEL: <b>IM-240NE,-21,-23</b> <b>IM-240WNE,-23</b>			TITLE: <b>D.CONTROL BOX ASSY</b>					
INDEX NO.	DESCRIPTION	MATERIAL OR MODEL NUMBER	PART NUMBER	REQ'D NUMBER				
				G-2 J-0	J-1	J-2 K-0	K-1	
1	CONTROL BOX B		3Y6722M01	1	1	1	1	
2	CONTROL BOX(B)		2X1251M01	1	1	1	1	
3	TRUSS HEAD TAPPING SCREW T2	(240NE,-21,-23)	FT20410F0	15	15	15	15	
		(240WNE,-23)		14	14	14	14	
4	BOARD SUPPORT		P04204-01	4	4	4	4	
5	CONTROLLER BOARD	(240NE,WNE)	P01873-01	-	-	-	-	
			P01873-02	1	1	1	1	
		(240NE-21)	P01873-01	1	1	1	-	
			P01873-02	-	-	-	1	
		(240NE-23) (240WNE-23)	P01873-01	1	1	-	-	
			P01873-02	-	-	1	1	
6	TRANSFORMER		P02714-01	1	1	1	1	
7	POWER RELAY		P00034-01	1	1	1	1	
8	CAPACITOR		P01870-01	2	2	2	2	
9	FUSE HOLDER		P02829-01	1	1	1	1	
10	FUSE		P04203-01	1	1	1	1	
11	GROMMET		4H2568-01	1	1	1	1	
12	GROMMET		4H2568-02	3	3	3	3	
20	CAPACITOR		P01910-01	1	1	1	1	
21	CAPACITOR	(240NE,-21,-23)	P01865-01	1	1	1	1	
22	CONTROL BOX - COVER		3Y6513M01	1	1	1	1	
23	CONTROL LABEL		475642L01	1	-	-	-	
	CONTROL LABEL(A)		481284L01	-	1	1	1	
24	LABEL - FUSE		466798-01	1	1	1	1	
25	TRUSS HEAD MACHINE SCREW		FST0408S0	1	1	1	1	
26	TIE		7920-0003	4	4	4	4	
27	SEPARATOR - BOX		3Y6512M01	1	1	1	1	

\*Note1 : From F00001 to F01133

\*Note2 : From F01134

IM-240NE(-21,-23)  
IM-240WNE(-23)

E. WATER CIRCUIT ASSY

(A-1) and later

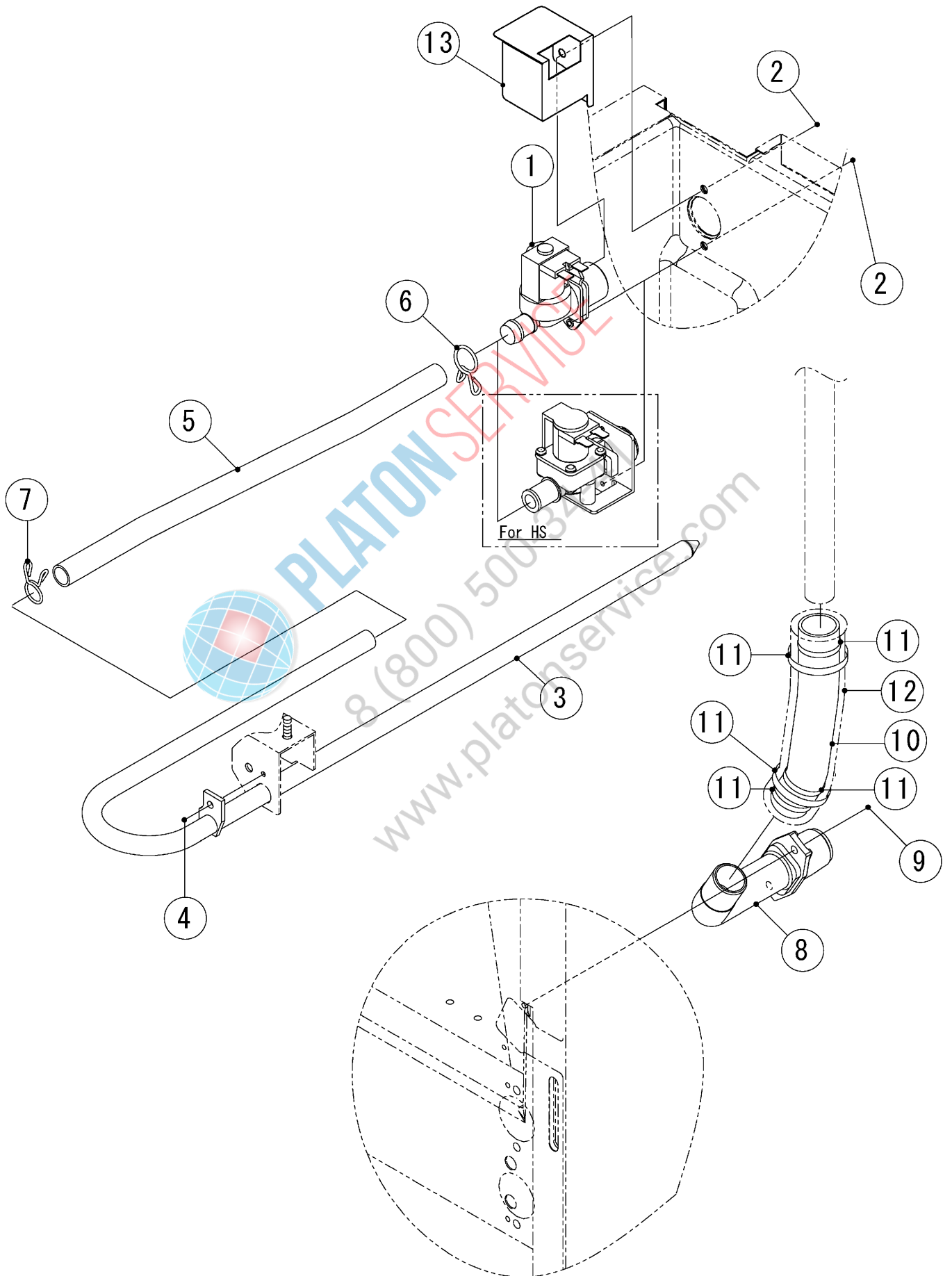

MODEL: <b>IM-240NE,-21,-23</b> <b>IM-240WNE,-23</b>			TITLE: <b>E.WATER CIRCUIT ASSY</b>					
INDEX NO.	DESCRIPTION	MATERIAL OR MODEL NUMBER	PART NUMBER	REQ'D NUMBER				
				A-1 B-1	B-2 B-3	B-4 F-0 (Note1)	F-0 (Note2) G-0	G-1
1	WATER VALVE		P05355-01	1	1	1	1	1
	WATER VALVE ASSY	HS ONLY	4Z0427A01	1	1	1	1	1
2	HEX HEAD BOLT (SPRING WASHER AND FLAT WASHER)		FBK0410S0	2	2	2	2	2
3	WATER SUPPLY PIPE		3H9533G01	1	1	1	1	1
4	TRUSS HEAD MACHINE SCREW		FST0408S0	1	1	1	1	1
5	SILICONE HOSE		4Y6912R02	1	1	1	1	1
6	HOSE CLAMP		435934-03	1	1	1	1	1
7	HOSE CLAMP		435934-02	1	1	1	1	1
8	DRAIN PIPE		3H0394-01	1	1	1	1	1
9	TRUSS HEAD TAPPING SCREW T2		FT20410M0	2	2	2	2	2
10	VINYL HOSE		2X0293-01	1	1	1	1	1
11	TIE	CV-150	7920-0003	5	5	5	5	5
12	INSULATION HOSE - DRAIN		4Y7055Z01	1	1	1	1	1
13	COVER-WATER VALVE		3Y6277M01	1	1	1	1	1
		HS ONLY	-	-	-	-	-	

\*Note1 : From F00001 to F01133

\*Note2 : From F01134



PLATON SERVICE  
 8 (800) 500-3474  
 www.platonservice.com

<b>MODEL: IM-240NE,-21,-23 IM-240WNE,-23</b>	<b>TITLE: E.WATER CIRCUIT ASSY</b>
--	------------------------------------

INDEX NO.	DESCRIPTION	MATERIAL OR MODEL NUMBER	PART NUMBER	REQ'D NUMBER				
				G-2 J-0	J-1	J-2 K-0	K-1	
1	WATER VALVE		P05355-01	1	1	1	1	
	WATER VALVE ASSY	HS ONLY	4Z0427A01	1	1	1	1	
2	HEX HEAD BOLT (SPRING WASHER AND FLAT WASHER)		FBK0410S0	2	2	2	2	
3	WATER SUPPLY PIPE		3H9533G01	1	1	1	1	
4	TRUSS HEAD MACHINE SCREW		FST0408S0	1	1	1	1	
5	SILICONE HOSE		4Y6912R02	1	1	1	1	
6	HOSE CLAMP		435934-03	1	1	1	1	
7	HOSE CLAMP		435934-02	1	1	1	1	
8	DRAIN PIPE		3H0394-01	1	1	1	1	
9	TRUSS HEAD TAPPING SCREW T2		FT20410M0	2	2	2	2	
10	VINYL HOSE		2X0293-01	1	1	1	1	
11	TIE	CV-150	7920-0003	5	5	5	5	
12	INSULATION HOSE - DRAIN		4Y7055Z01	1	1	1	1	
13	COVER-WATER VALVE		3Y6277M01	1	1	1	1	
		HS ONLY	-	-	-	-	-	



PLATON SERVICE

8 (800) 500-3722

www.platonservice.com

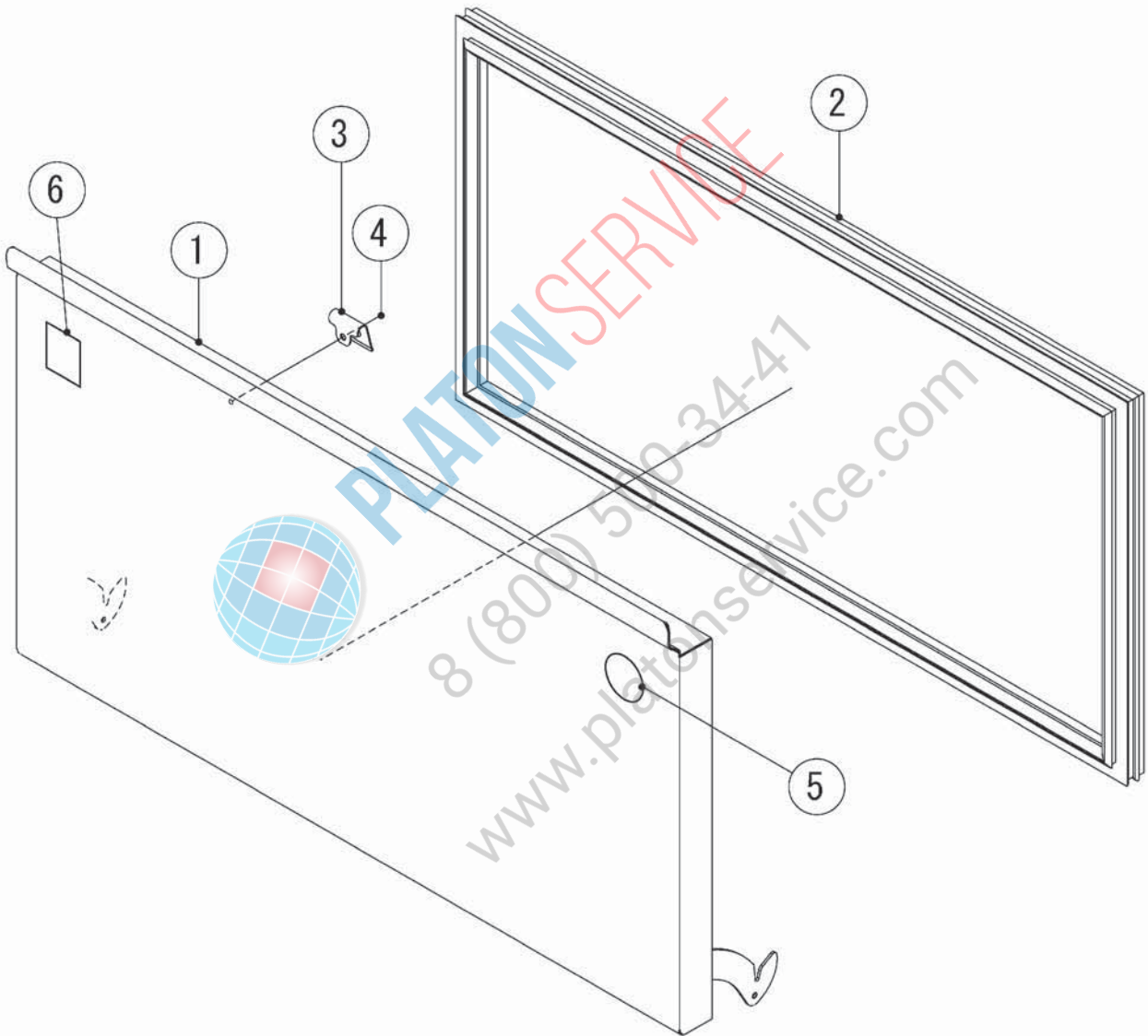



MODEL: <b>IM-240NE,-21,-23</b> <b>IM-240WNE,-23</b>			TITLE: <b>F.DOOR ASSY</b>					
INDEX NO.	DESCRIPTION	MATERIAL OR MODEL NUMBER	PART	REQ'D NUMBER				
			NUMBER	A-1 B-1	B-2 B-3	B-4 F-0 (Note1)	F-0 (Note2) G-0	G-1
1	DOOR G		3Y5435G01	1	1	1	1	1
2	DOOR GASKET		3Y8291P04	1	1	1	1	1
3	CATCH - SLOPE		4X7644-01	1	1	1	1	1
4	TRUSS HEAD TAPPING SCREW T2		FT20408M0	1	1	1	1	1
5	LABEL - PENGUIN	(HE)	468184-01	1	1	1	1	1
6	LABEL - HACCP		476519L01	1	1	1	1	1

\*Note1 : From F00001 to F01133

\*Note2 : From F01134



**PLATON SERVICE**

8 (800) 500-34-41

www.platonservice.com

MODEL: <b>IM-240NE,-21,-23</b> <b>IM-240WNE,-23</b>				TITLE: <b>F.DOOR ASSY</b>				
INDEX NO.	DESCRIPTION	MATERIAL OR MODEL NUMBER	PART NUMBER	REQ'D NUMBER				
				G-2 J-0	J-1	J-2 K-0	K-1	
1	DOOR G		3Y5435G01	1	1	1	1	
2	DOOR GASKET		3Y8291P04	1	1	1	1	
3	CATCH - SLOPE		4X7644-01	1	1	1	1	
4	TRUSS HEAD TAPPING SCREW T2		FT20408M0	1	1	1	1	
5	LABEL - PENGUIN	(HE)	468184-01	1	1	1	1	
6	LABEL - HACCP		476519L01	1	1	1	1	



**PLATON SERVICE**

8 (800) 500-34-47

www.platonservice.com

IM-240NE(-21,-23)

IM-240WNE(-23)

G. FRONT COVER UPPER ASSY (A-1) and later

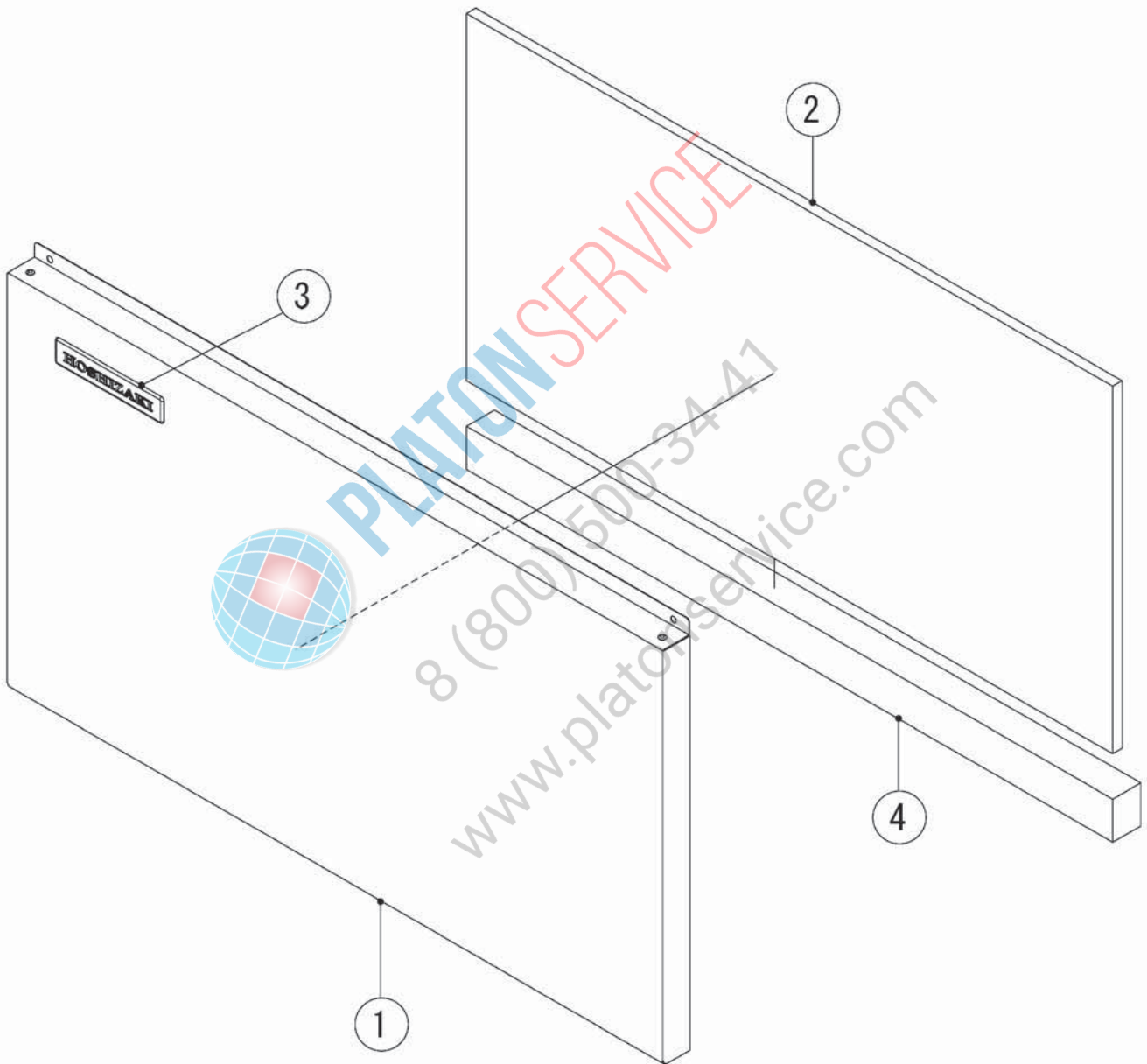

MODEL: <b>IM-240NE,-21,-23</b> <b>IM-240WNE,-23</b>			TITLE: <b>G.FRONT COVER UPPER ASSY</b>					
INDEX NO.	DESCRIPTION	MATERIAL OR MODEL NUMBER	PART NUMBER	REQ'D NUMBER				
				A-1 B-1	B-2 B-3	B-4 F-0 (Note1)	F-0 (Note2) G-0	G-1
1	FRONT COVER UPPER		3Y5437G01	1	1	1	1	1
2	INSULATION - FRONT(A)		4Y7327P01	1	1	1	1	1
3	EMBLEM	(HE)	340842-01	1	1	1	1	1
	EMBLEM-GRAM	(GRAM)	4Y6123L01	-	-	1	1	1
4	INSULATION - FRONT(B)		4Y7328P01	1	1	1	1	1

\*Note1 : From F00001 to F01133

\*Note2 : From F01134



**PLATON SERVICE**

8 (800) 500-34-41

www.platonservice.com

MODEL: <b>IM-240NE,-21,-23</b> <b>IM-240WNE,-23</b>				TITLE: <b>G.FRONT COVER UPPER ASSY</b>				
INDEX NO.	DESCRIPTION	MATERIAL OR MODEL NUMBER	PART NUMBER	REQ'D NUMBER				
				G-2 J-0	J-1	J-2 K-0	K-1	
1	FRONT COVER UPPER		3Y5437G01	1	1	1	1	
2	INSULATION - FRONT(A)		4Y7327P01	1	1	1	1	
3	EMBLEM	(HE)	340842-01	1	1	1	1	
	EMBLEM-GRAM	(GRAM)	4Y6123L01	1	1	1	1	
4	INSULATION - FRONT(B)		4Y7328P01	1	1	1	1	



**PLATON SERVICE**

8 (800) 500-34-41

www.platonservice.com

IM-240NE(-21,-23)

IM-240WNE(-23) H. FRONT COVER (LOWER) ASSY (A-1) and later

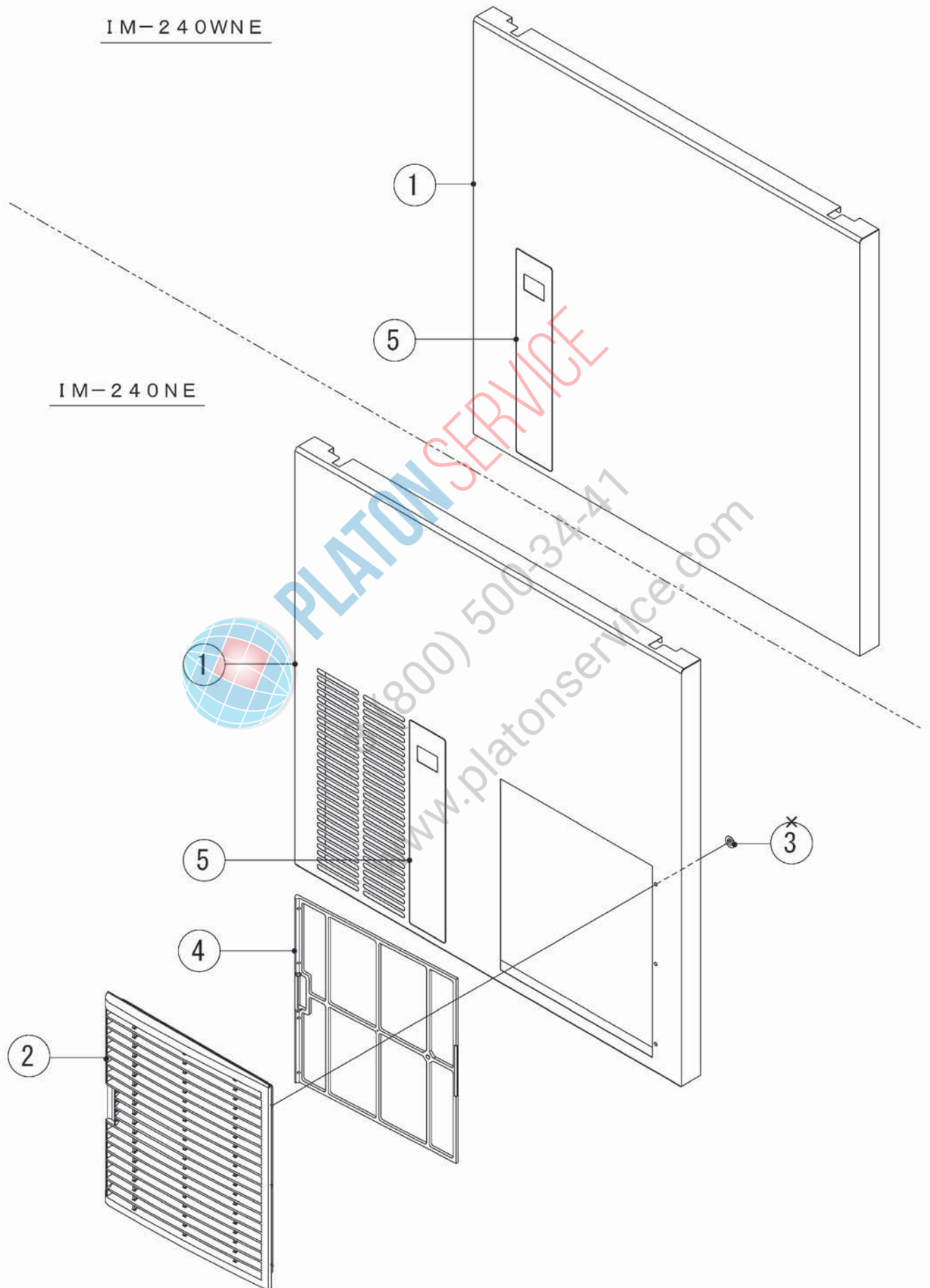

MODEL: <b>IM-240NE,-21,-23</b> <b>IM-240WNE,-23</b>			TITLE: <b>H.FRONTCOVER(LOWER) ASSY</b>					
INDEX NO.	DESCRIPTION	MATERIAL OR MODEL NUMBER	PART NUMBER	REQ'D NUMBER				
				A-1 B-1	B-2 B-3	B-4 F-0 (Note1)	F-0 (Note2) G-0	G-1
1	FRONT COVER LOWER	(240NE,-21,-23)	3Y5546G01	1	-	-	-	-
			3Y6769G01	-	1	1	1	1
		(240WNE,-23)	3Y5545G01	1	-	-	-	-
			3Y6775G01	-	1	1	1	1
2	LOUVER A	(240NE,-21,-23)	1A0547-01	1	-	-	-	-
			121931P01	-	1	1	1	1
3	PUSH RETAINER	(240NE,-23)	4A2414-01	3	-	-	-	-
4	AIR FILTER A	(240NE,-21,-23)	2A2062G01	1	-	-	-	-
			262259G01	-	1	1	1	1
5	OPERATION LABEL		375116L01	1	-	-	-	-
			375116L04	-	1	1	1	1

\*Note1 : From F00001 to F01133

\*Note2 : From F01134



**PLATON SERVICE**  
8 (800) 500-34-41  
www.platonservice.com

MODEL: <b>IM-240NE,-21,-23</b> <b>IM-240WNE,-23</b>				TITLE: <b>H.FRONTCOVER(LOWER) ASSY</b>				
INDEX NO.	DESCRIPTION	MATERIAL OR MODEL NUMBER	PART NUMBER	REQ'D NUMBER				
				G-2 J-0	J-1	J-2 K-0	K-1	
1	FRONT COVER LOWER	(240NE,-21,-23)	3Y6769G01	1	1	1	1	
		(240WNE,-23)	3Y6775G01	1	1	1	1	
2	LOUVER A	(240NE,-21,-23)	121931P01	1	1	1	1	
4	AIR FILTER A	(240NE,-21,-23)	262259G01	1	1	1	1	
5	OPERATION LABEL		375116L04	1	1	1	1	



**PLATON SERVICE**

8 (800) 500-34-41

www.platonservice.com



IM-240NE(-21,-23)

IM-240WNE(-23)

J. ACTUATOR MOTOR ASSY

(A-1) and later

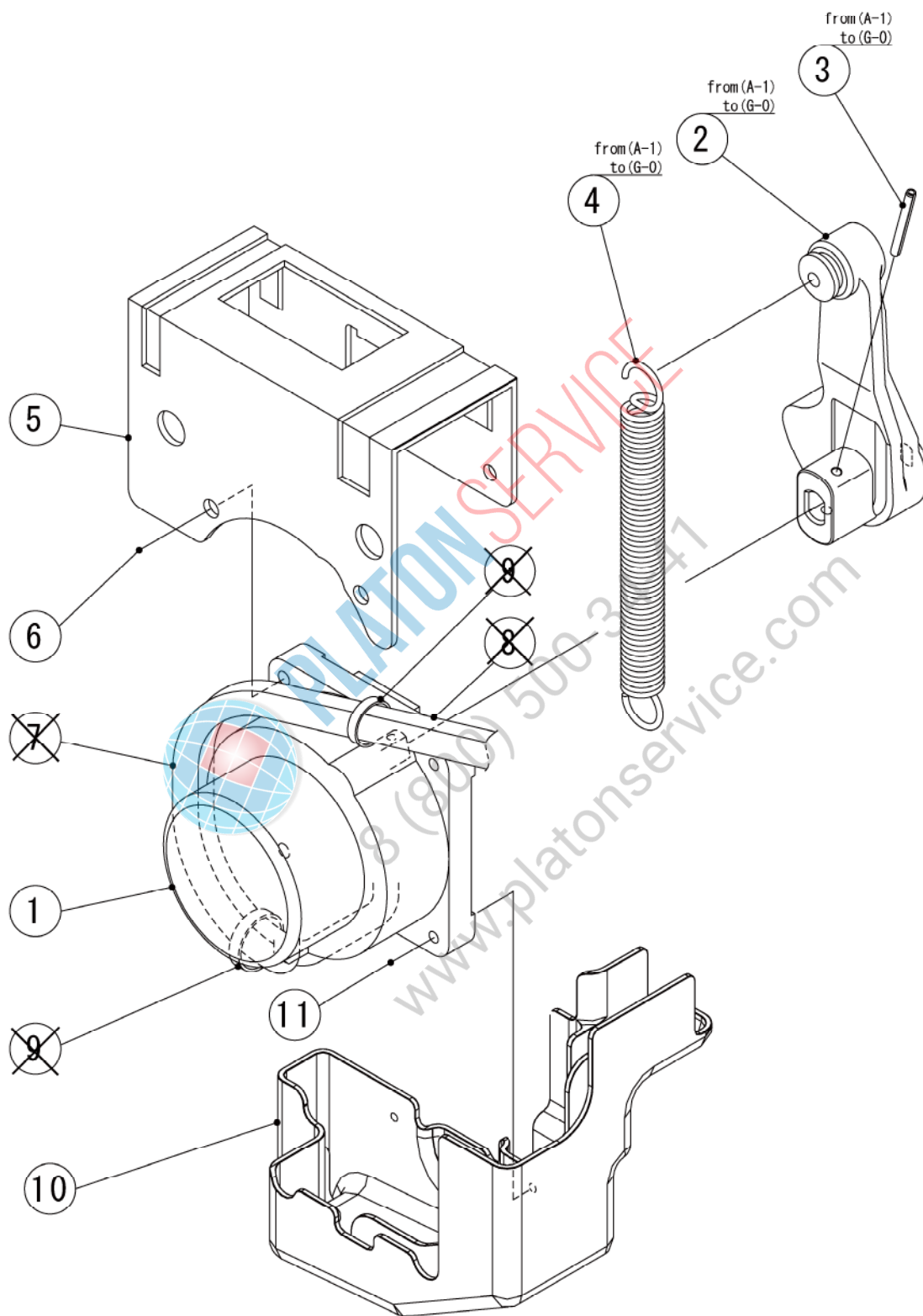

MODEL: <b>IM-240NE,-21,-23</b> <b>IM-240WNE,-23</b>			TITLE: <b>J.ACTUATOR MOTOR ASSY</b>					
INDEX NO.	DESCRIPTION	MATERIAL OR MODEL NUMBER	PART NUMBER	REQ'D NUMBER				
				A-1 B-1	B-2 B-3	B-4 F-0 (Note1)	F-0 (Note2) G-0	G-1
1	ACTUATOR MOTOR		4Y8998G01	1	1	1	1	1
2	CAM(A)		306543G03	1	1	1	1	-
3	SPRING PIN	3*28	712S-0328	1	1	1	1	-
4	EXTEN SPRING		4H3473-01	1	1	1	1	-
5	BRACKET - AM		3Y2924M01	1	1	1	1	1
6	HEX HEAD BOLT (SPRING WASHER AND FLAT WASHER)		FBK0620S0	2	2	2	2	2
7	TUBE-SILICONE		4Y6751Z03	-	-	-	-	-
8	TUBE-SILICONE		4X8017-07	-	-	-	-	-
9	TIE	CV-150	7920-0003	-	-	-	-	-
10	COVER - ACTUATOR MOTOR		1H4881P01	1	1	1	1	1
11	T2 TRUSS HEAD SCREW		FT20416M0	2	2	2	2	2

\*Note1 : From F00001 to F01133

\*Note2 : From F01134



PLATON SERVICE  
 8 (800) 500-34-41  
 www.platonservice.com

MODEL: <b>IM-240NE,-21,-23</b> <b>IM-240WNE,-23</b>				TITLE: <b>J.ACTUATOR MOTOR ASSY</b>				
INDEX NO.	DESCRIPTION	MATERIAL OR MODEL NUMBER	PART NUMBER	REQ'D NUMBER				
				G-2 J-0	J-1	J-2 K-0	K-1	
1	ACTUATOR MOTOR		4Y8998G01	1	1	1	1	
5	BRACKET - AM		3Y2924M01	1	1	1	1	
6	HEX HEAD BOLT (SPRING WASHER AND FLAT WASHER)		FBK0620S0	2	2	2	2	
10	COVER - ACTUATOR MOTOR		1H4881P01	1	1	1	1	
11	T2 TRUSS HEAD SCREW		FT20416M0	2	2	2	2	



**PLATON SERVICE**

8 (800) 500-34-41

www.platonservice.com

IM-240NE(-21,-23)  
IM-240WNE(-23)

### K. WATER PAN ASSY

(A-1) and later

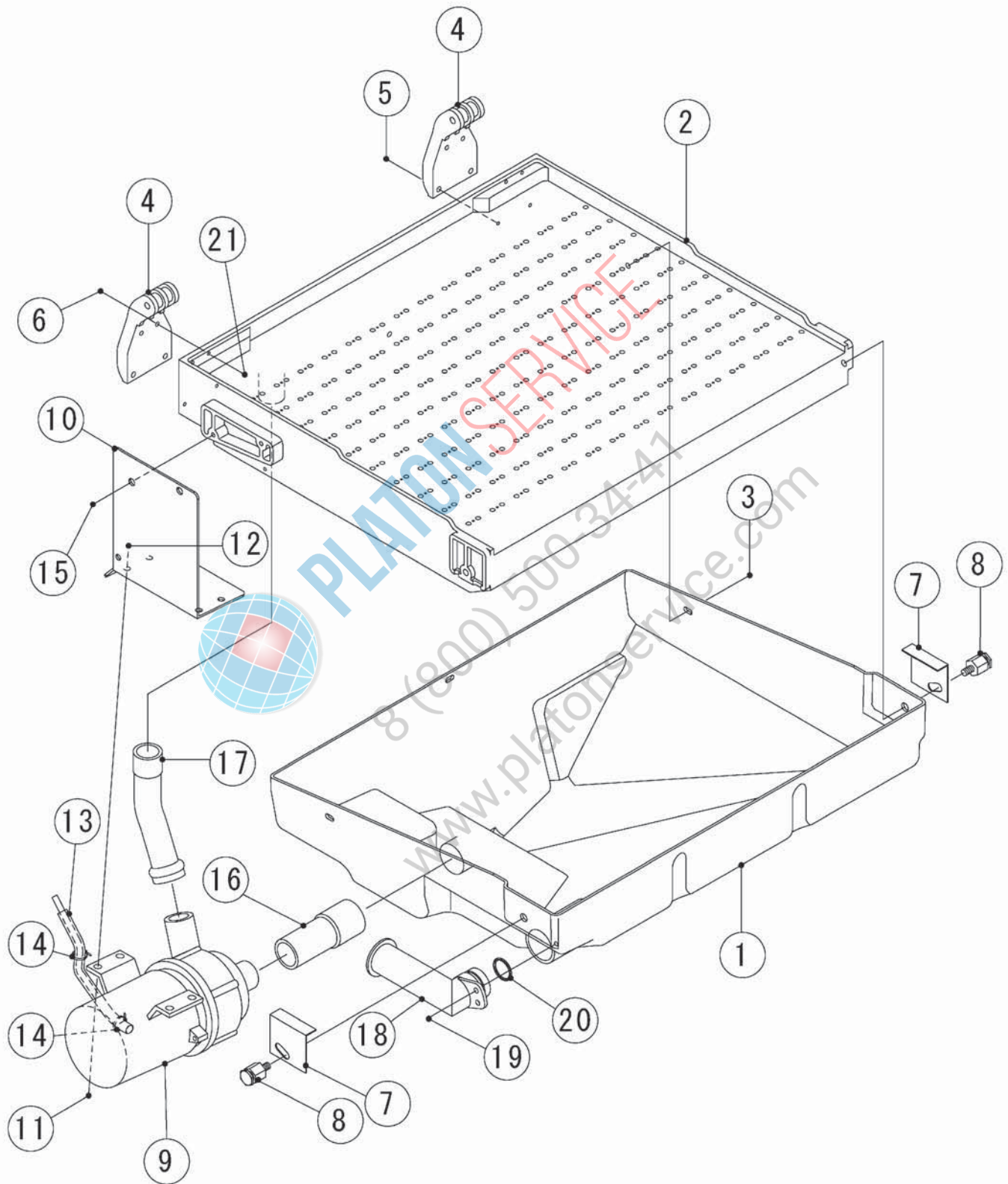

MODEL: <b>IM-240NE,-21,-23</b> <b>IM-240WNE,-23</b>			TITLE: <b>K.WATER PAN ASSY</b>					
INDEX NO.	DESCRIPTION	MATERIAL OR MODEL NUMBER	PART NUMBER	REQ'D NUMBER				
				A-1 B-1	B-2 B-3	B-4 F-0 (Note1)	F-0 (Note2) G-0	G-1
1	WATER PAN		1H0888-02	1	1	1	1	1
2	WATER PLATE		208020G01	1	1	1	1	1
		(240NE-21)	208484G01	-	1	1	1	1
3	TRUSS HEAD TAPPING SCREW T2		FT20406M0	3	3	3	3	3
	TRUSS HEAD SCREW	(240NE-21)	FST0408S0	-	3	3	3	3
4	WATER PAN HANGER		3H2059-01	2	2	2	2	2
5	TRUSS HEAD TAPPING SCREW T2		FT20416M0	4	4	4	4	4
	TRUSS HEAD MACHINE SCREW	(240NE-21)	FST0420S0	-	4	4	4	4
6	TRUSS HEAD TAPPING SCREW T2		FT20425M0	4	4	4	4	4
	TRUSS HEAD SCREW	(240NE-21)	FST0425S0	-	4	4	4	4
7	BRACKET		402957-01	2	2	2	2	2
8	SCREW SPRING HOOK		4H2582G01	2	2	2	2	2
9	PUMP MOTOR	PMX-352BHZ1S	P02715-01	1	1	1	1	1
10	BRACKET - PUMP		4Y6617M01	1	1	1	1	1
11	HEX HEAD BOLT		FBK0412S0	4	4	4	4	4
	(SPRING WASHER AND FLAT WASHER)							
12	FLANGE NUT		FNHF04S0	4	4	4	4	4
13	TUBE - SILICONE		4Y6751Z10	1	1	1	1	1
14	NYLON TIE	CV-100	7920-0002	2	2	2	2	2
15	TRUSS HEAD TAPPING SCREW T2		FT20516M0	2	2	2	2	2
	TRUSS HEAD SCREW	(240NE-21)	FST0516S0	-	2	2	2	2
16	SUCTION TUBE		4Y6641R01	1	1	1	1	1
17	DISCHARGE TUBE		4Y6642R01	1	1	1	1	1
18	PIPE - DRAIN		315530-01	1	1	1	1	1
19	TRUSS HEAD MACHINE SCREW		FST0410S0	1	1	1	1	1
20	O-RING		7611-G025	1	1	1	1	1
21	NUT	(240NE-21)	FNH104S0	-	4	4	4	4

\*Note1 : From F00001 to F01133

\*Note2 : From F01134



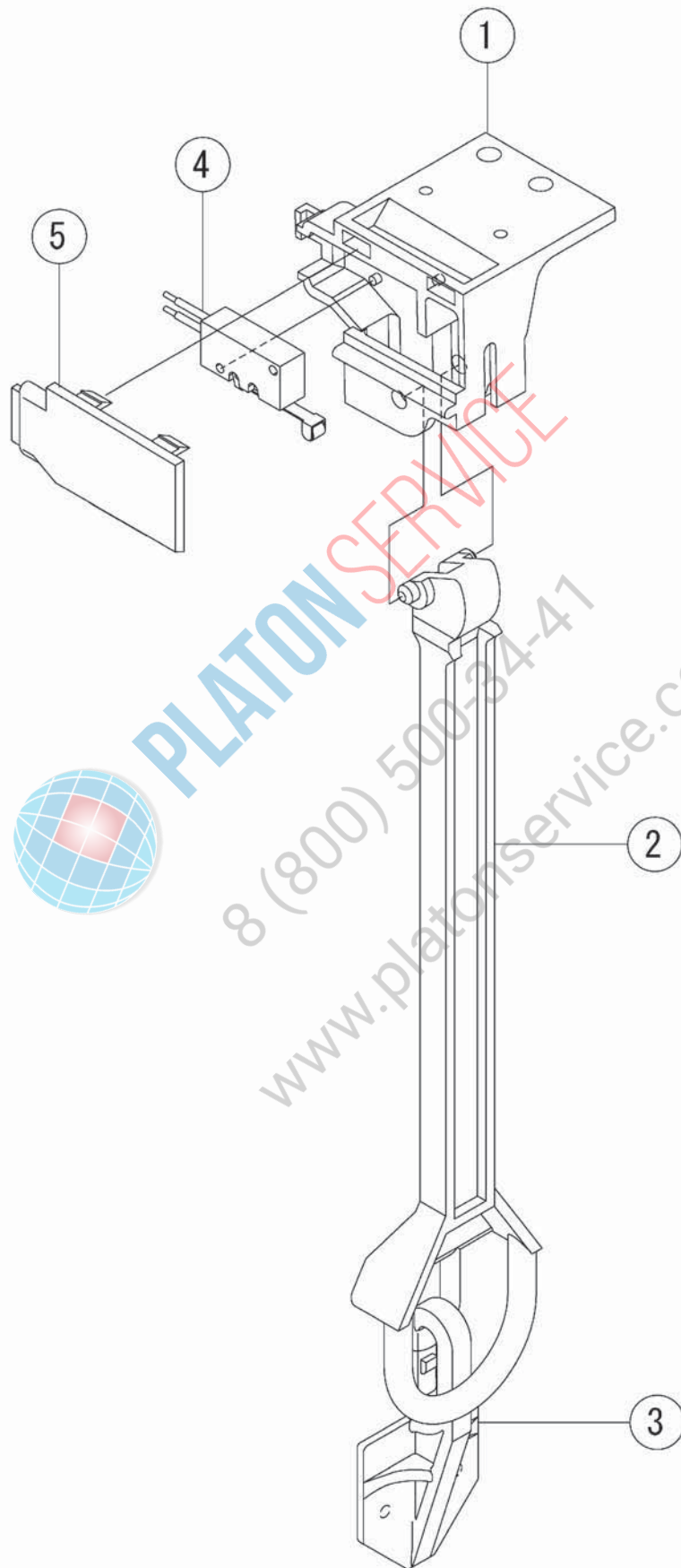

MODEL: <b>IM-240NE,-21,-23</b> <b>IM-240WNE,-23</b>			TITLE: <b>L.BIN SWITCH AY</b>					
INDEX NO.	DESCRIPTION	MATERIAL OR MODEL NUMBER	PART NUMBER	REQ'D NUMBER				
				A-1 B-1	B-2 B-3	B-4 F-0 (Note1)	F-0 (Note2) G-0	G-1
1	SWICH BOX		2H2043-01	1	1	1	1	1
2	SWITCH ACTUATOR		3H1369-02	1	1	1	1	1
3	DETECTOR		311044-01	1	1	1	1	1
4	MICRO SWITCH		456432-02	1	1	1	1	1
5	SWITCH BOX COVER		4H8785-01	1	1	1	1	1

\*Note1 : From F00001 to F01133

\*Note2 : From F01134



**PLATON SERVICE**

8 (800) 500-34-41

www.platonservice.com



MODEL: <b>IM-240NE,-21,-23</b> <b>IM-240WNE,-23</b>				TITLE: <b>L.BIN SWITCH AY</b>				
INDEX NO.	DESCRIPTION	MATERIAL OR MODEL NUMBER	PART NUMBER	REQ'D NUMBER				
				G-2 J-0	J-1	J-2 K-0	K-1	
1	SWICH BOX		2H2043-01	1	1	1	1	
2	SWITCH ACTUATOR		3H1369-02	1	1	1	1	
3	DETECTOR		311044-01	1	1	1	1	
4	MICRO SWITCH		456432-02	1	1	1	1	
5	SWITCH BOX COVER		4H8785-01	1	1	1	1	



**PLATON SERVICE**

8 (800) 500-34-47

www.platonservice.com

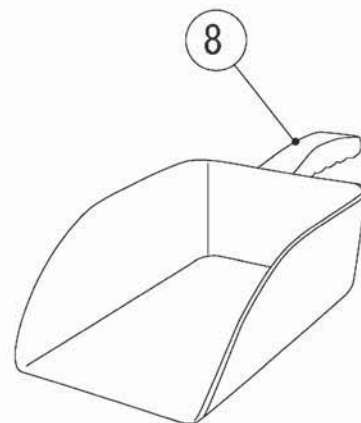
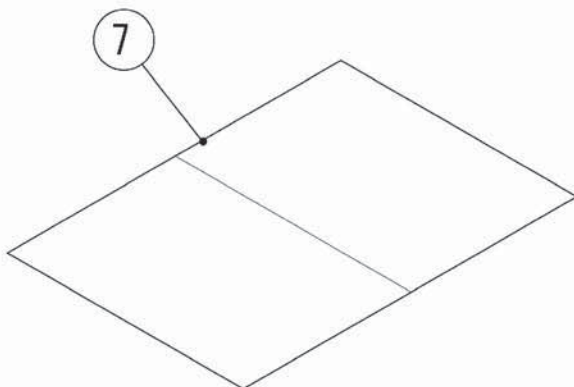
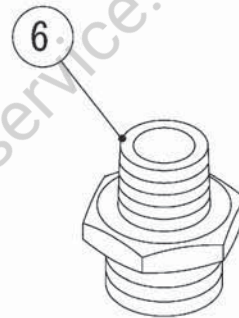
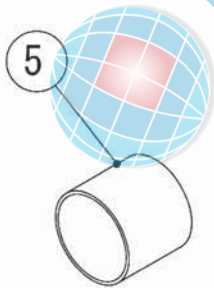
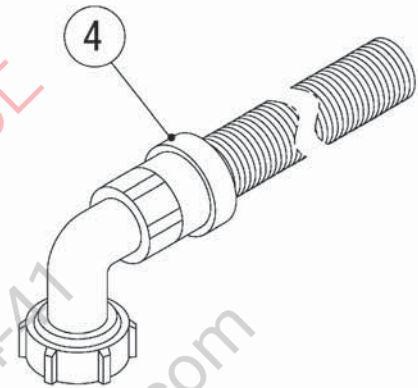
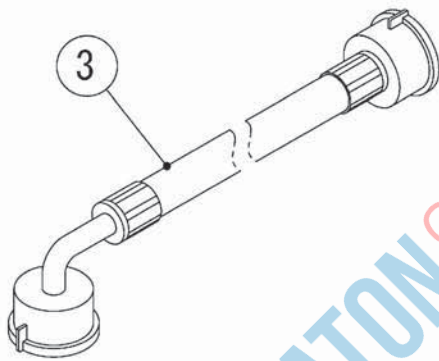
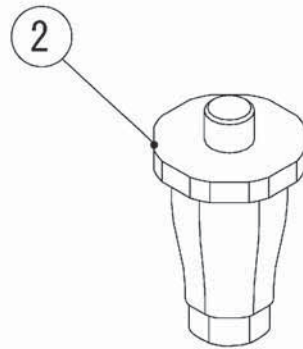
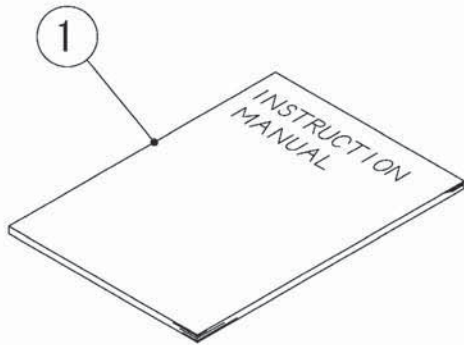

PLATON SERVICE  
8 (800) 500-34-47  
www.platonservice.com

MODEL: <b>IM-240NE,-21,-23</b> <b>IM-240WNE,-23</b>			TITLE: <b>M.ACCESSORIES</b>					
INDEX NO.	DESCRIPTION	MATERIAL OR MODEL NUMBER	PART NUMBER	REQ'D NUMBER				
				A-1 B-1	B-2 B-3	B-4 F-0 (Note1)	F-0 (Note2) G-0	G-1
1	INSTRUCTION MANUAL		L1E1EC203	1	1	1	1	1
		(CHINA)	L1E1EC301	1	1	1	1	1
		(HL)	L1E1EC113	-	-	-	1	1
2	LEG	SDKO-90H-NS □ SDKO-90HE-NS	446729-01	4	4	4	4	4
3	INLET HOSE	(240NE,-21,-23)	P03534-01	1	1	1	1	1
		(240WNE,-23)		2	2	2	2	2
4	OUTLET HOSE	(240NE,-21,-23)	452365-01	1	1	1	1	1
		(240WNE,-23)		2	2	2	2	2
5	CAP		417323-01	1	1	1	1	1
6	ADAPTOR	(240WNE,-23)	450724-01	2	2	2	2	2
7	INSTRUCTION SHEET		121594L01	1	1	1	1	1
8	SCOOP		P00315-01	1	1	1	1	1

\*Note1 : From F00001 to F01133

\*Note2 : From F01134



**PLATON SERVICE**  
 8 (800) 500-34-41  
 www.platonservice.com

MODEL: <b>IM-240NE,-21,-23</b> <b>IM-240WNE,-23</b>				TITLE: <b>M.ACCESSORIES</b>				
INDEX NO.	DESCRIPTION	MATERIAL OR MODEL NUMBER	PART NUMBER	REQ'D NUMBER				
				G-2 J-0	J-1	J-2 K-0	K-1	
1	INSTRUCTION MANUAL		L1E1EC203	1	1	1	1	
		(CHINA)	L1E1EC301	1	1	1	1	
		(HL)	L1E1EC113	1	1	1	1	
2	LEG	SDKO-90H-NS □ SDKO-90HE-NS	446729-01	4	4	4	4	
3	INLET HOSE	(240NE,-21,-23)	P03534-01	1	1	1	1	
		(240WNE,-23)		2	2	2	2	
4	OUTLET HOSE	(240NE,-21,-23)	452365-01	1	1	1	1	
		(240WNE,-23)		2	2	2	2	
5	CAP		417323-01	1	1	1	1	
6	ADAPTOR	(240WNE,-23)	450724-01	2	2	2	2	
7	INSTRUCTION SHEET		121594L01	1	1	1	1	
8	SCOOP		P00315-01	1	1	1	1	



**PLATON SERVICE**  
 8 (800) 500-34-41  
[www.platonservice.com](http://www.platonservice.com)